

A B R I S D E P I S C I N E

ZENITH AQBOX

GUIDE GÉNÉRAL

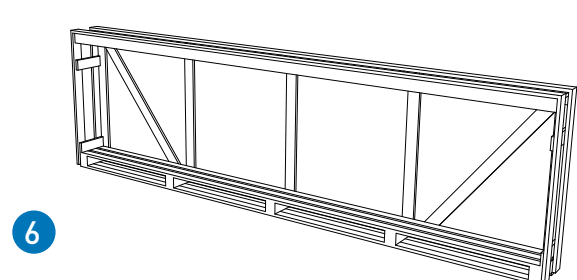

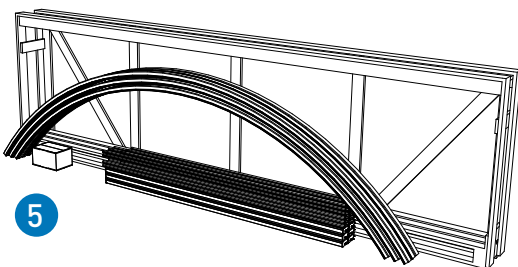
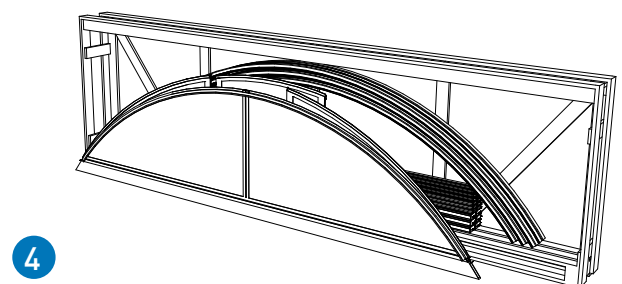
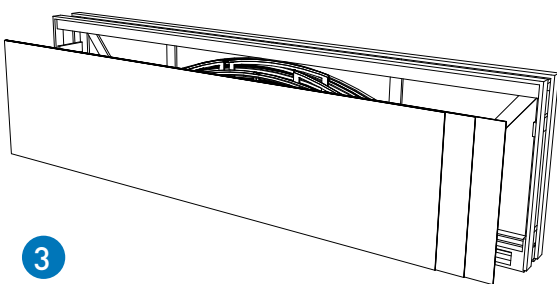
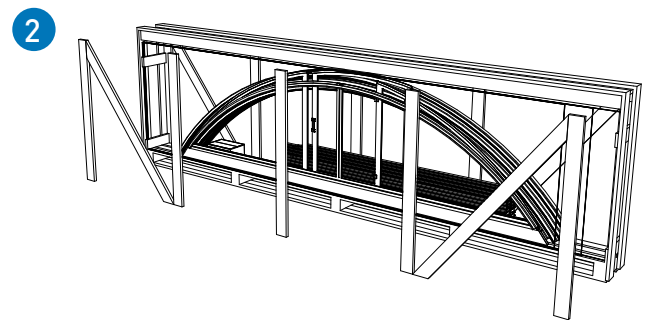
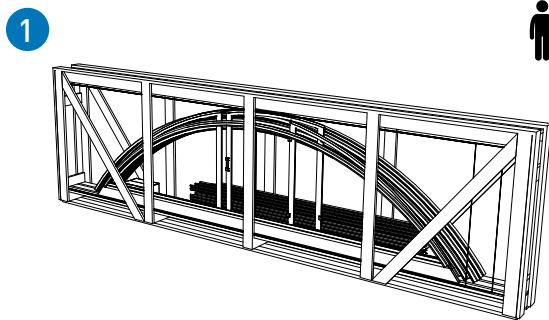

# 1 DÉMONTAGE DE LA CAISSE

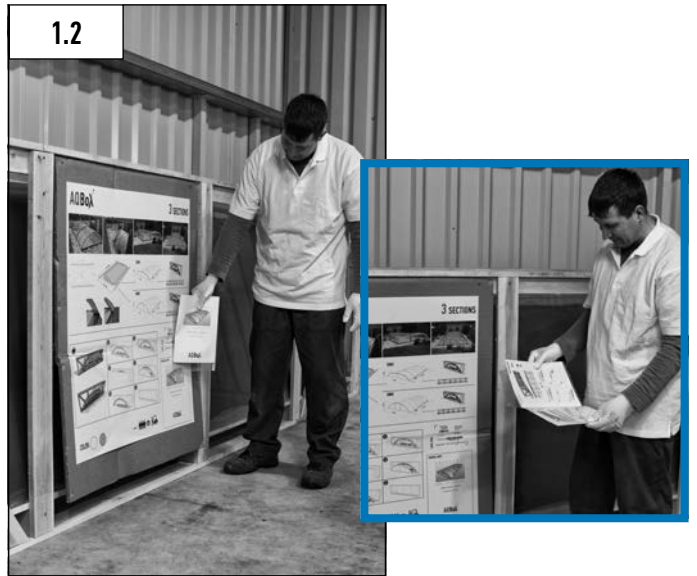

# 1 DÉMONTAGE DE LA CAISSE

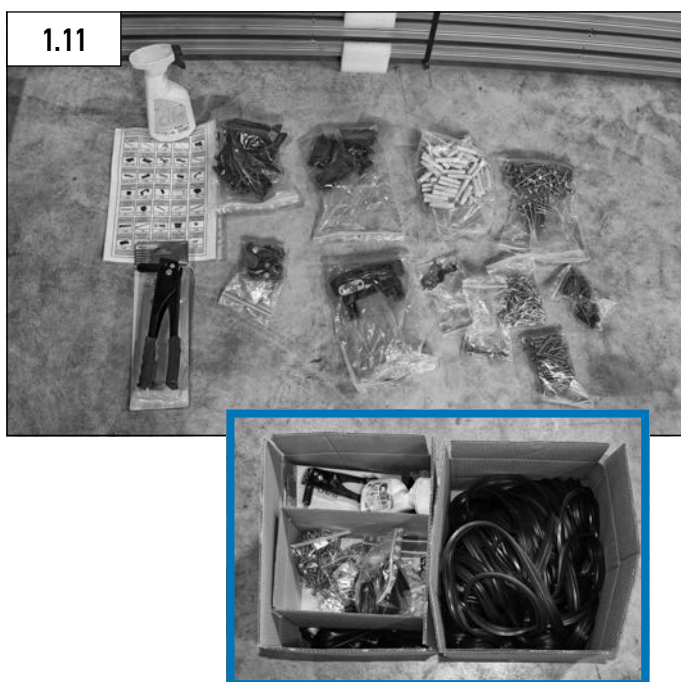
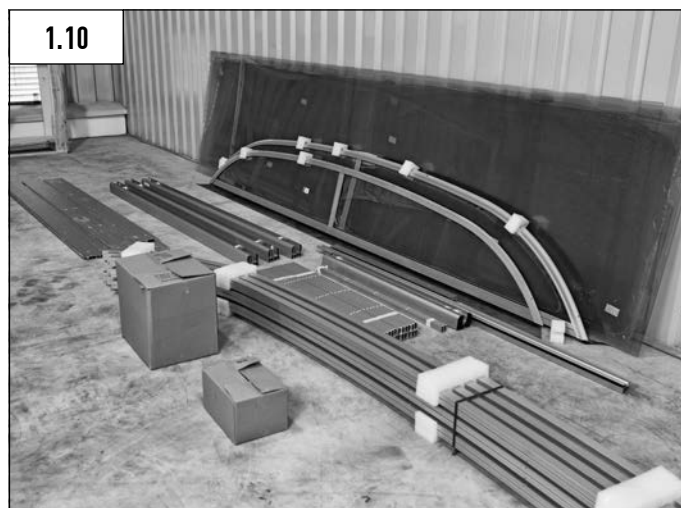
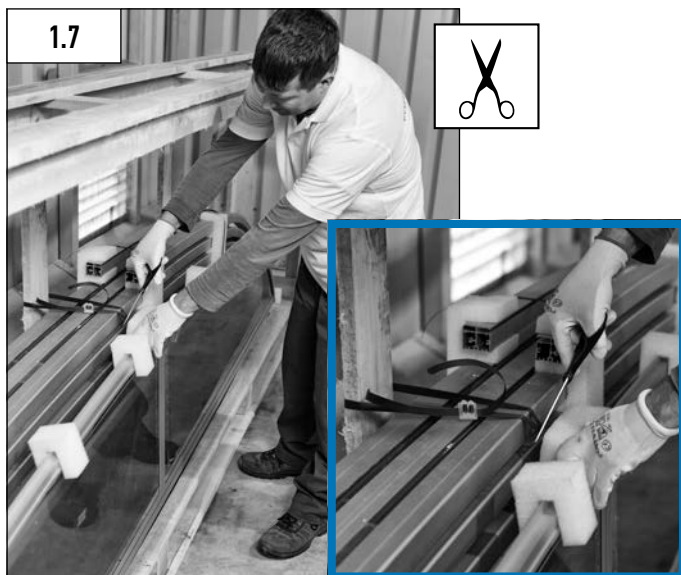

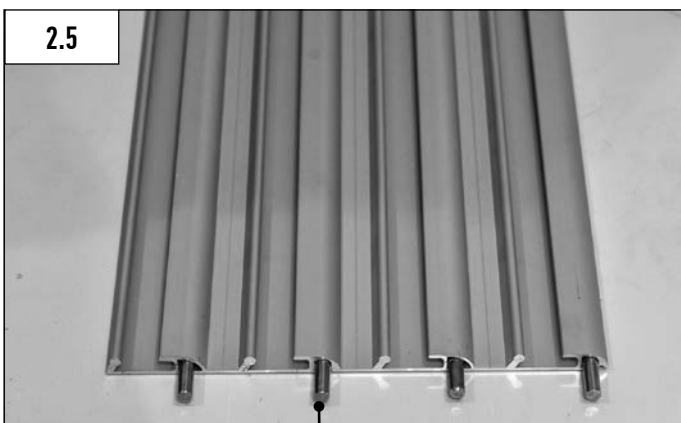
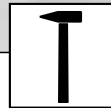
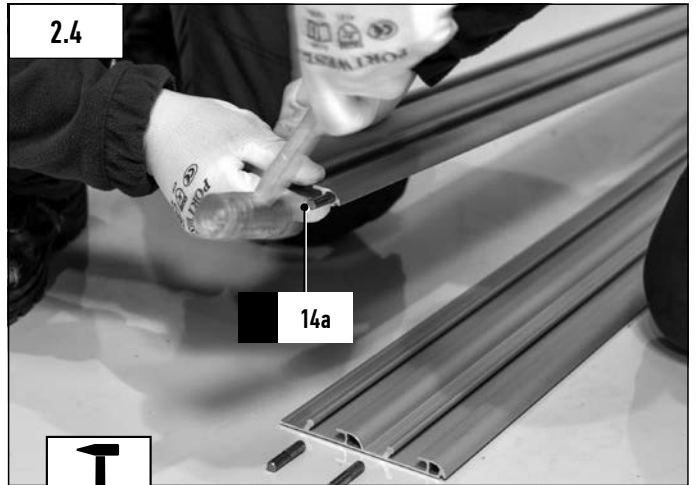
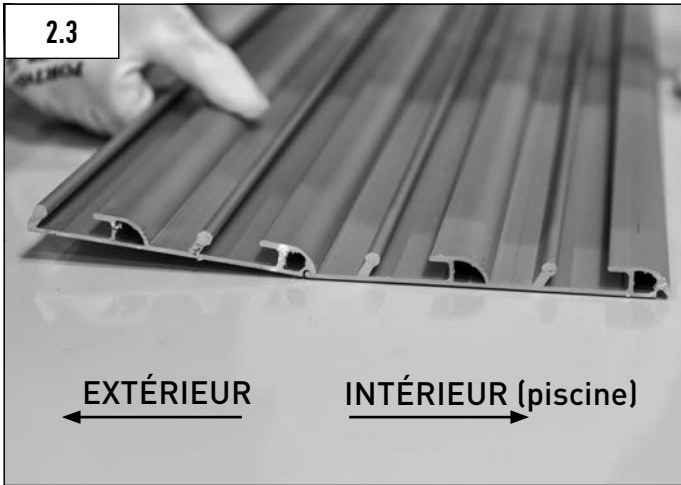

Dans le cas de A4, A3/4 et A4S,  
NE PAS installer la 2eme jonction  
de platine comptant de  
l'extérieure!

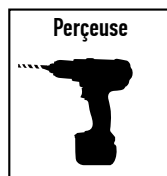
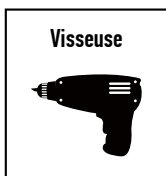
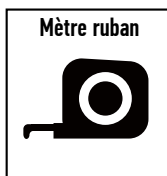
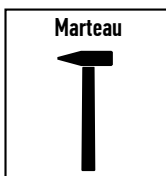
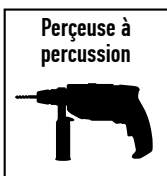
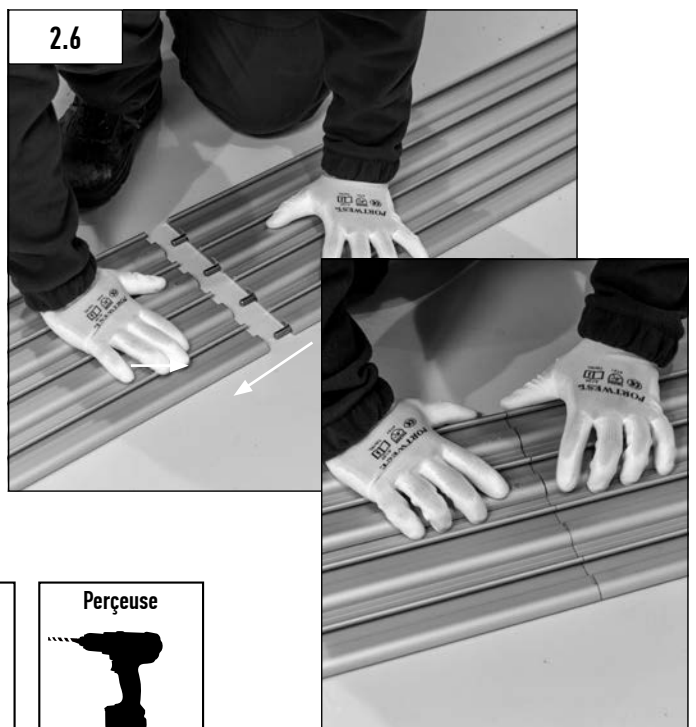

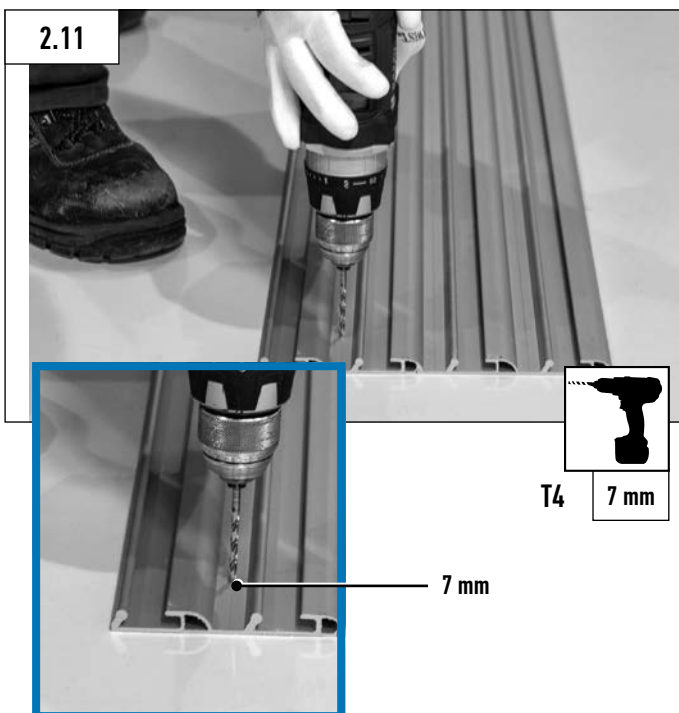
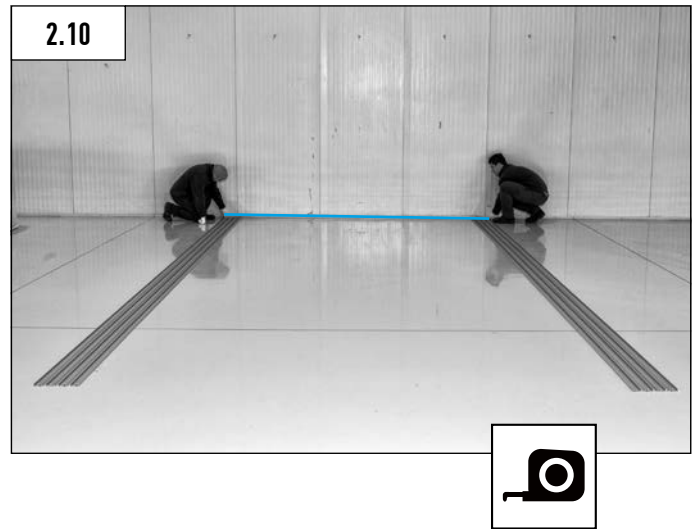
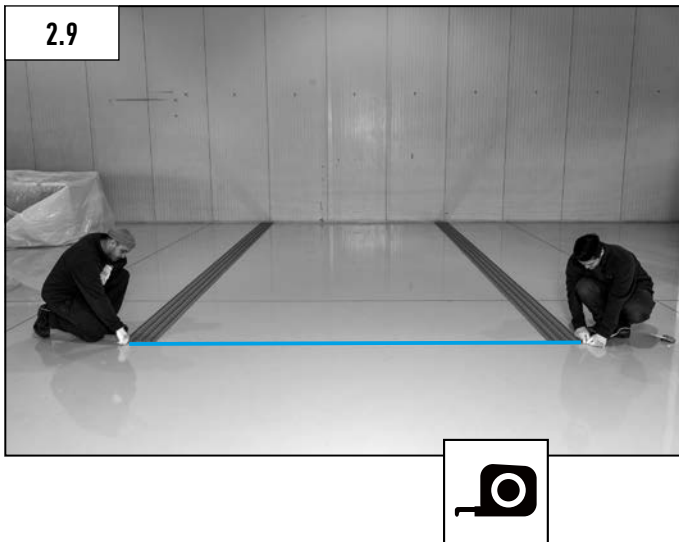
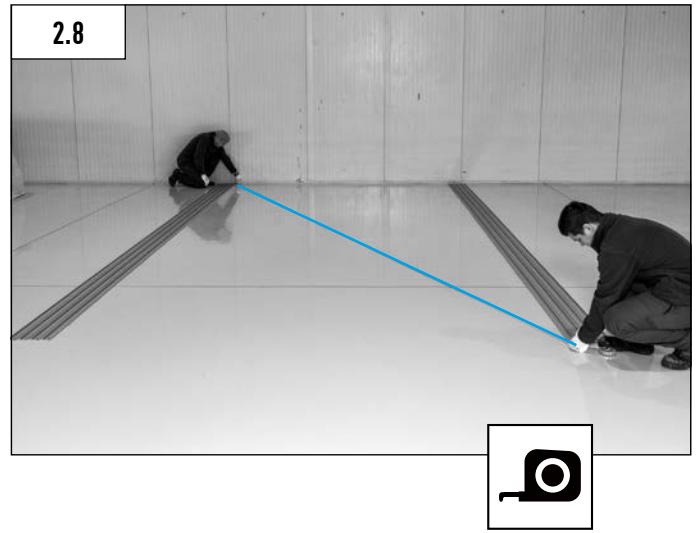
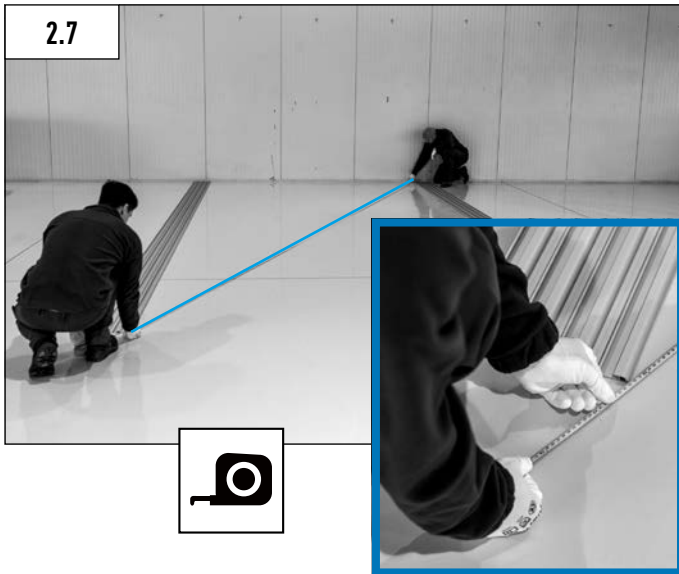

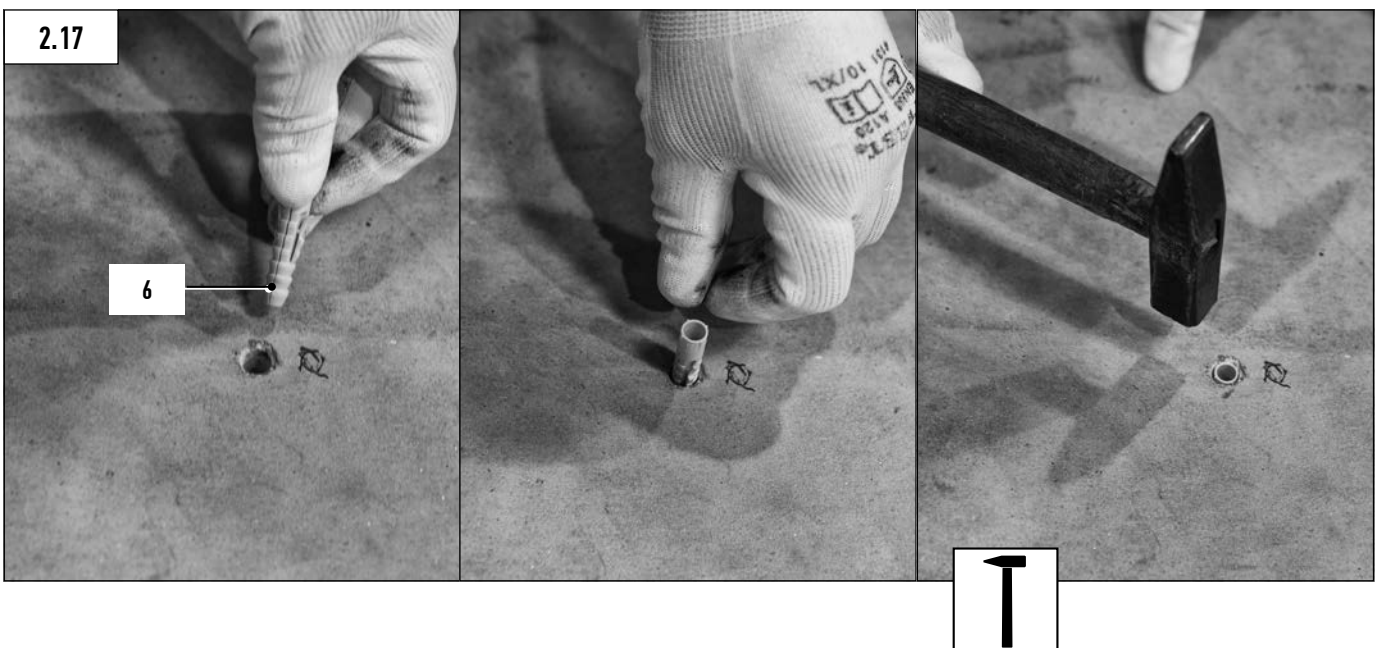
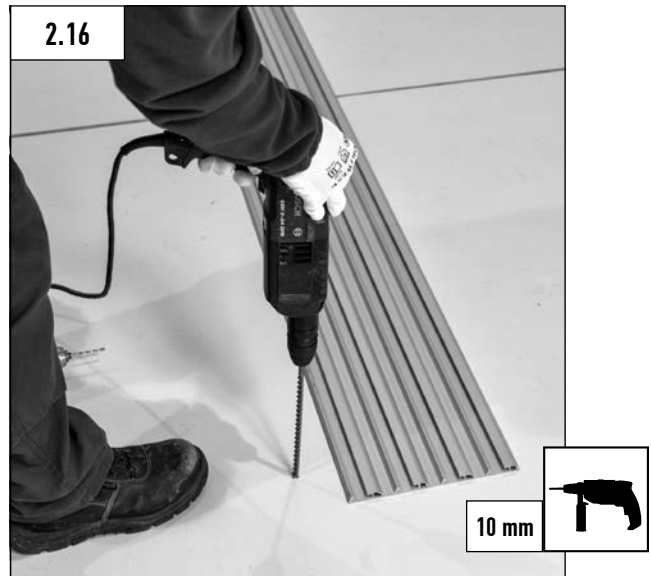
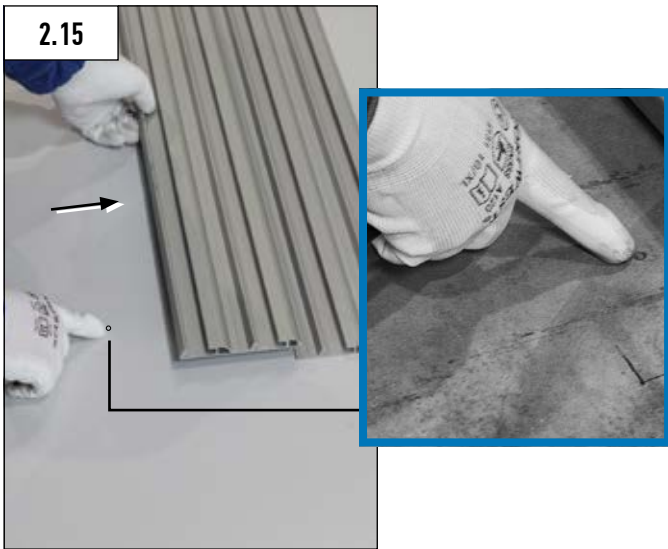
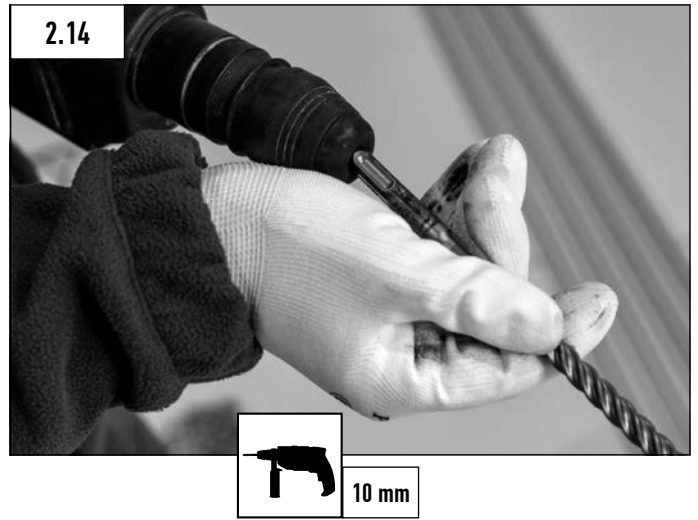
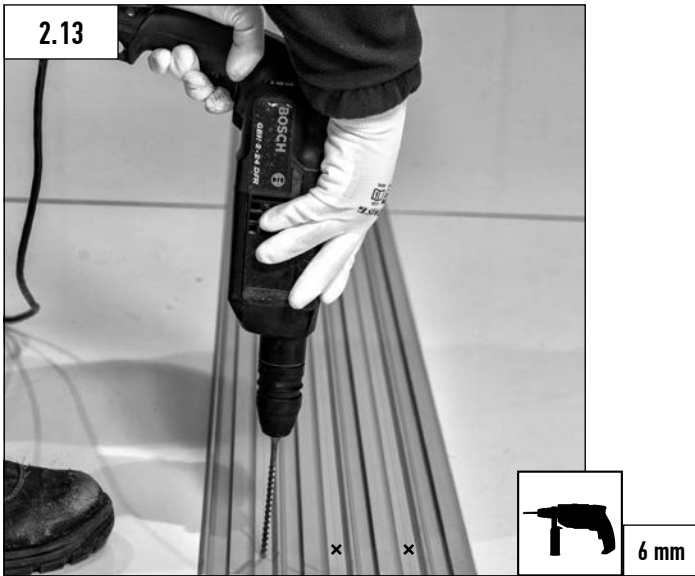



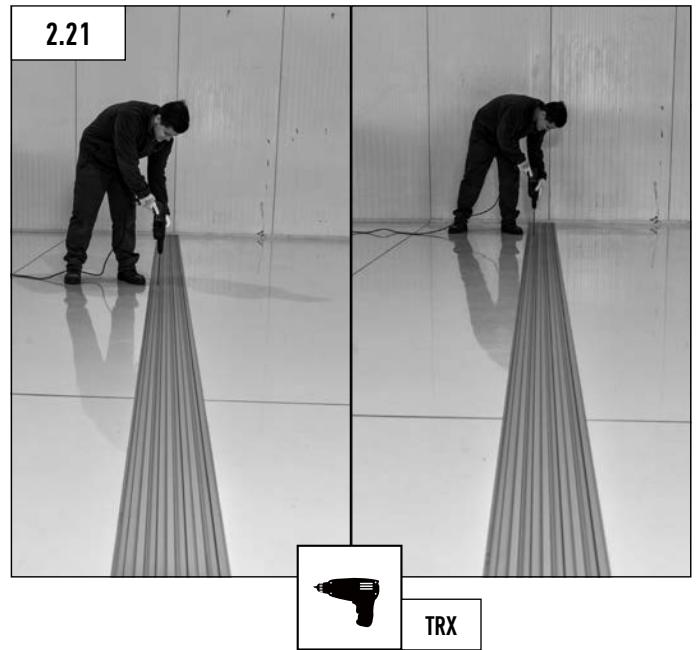
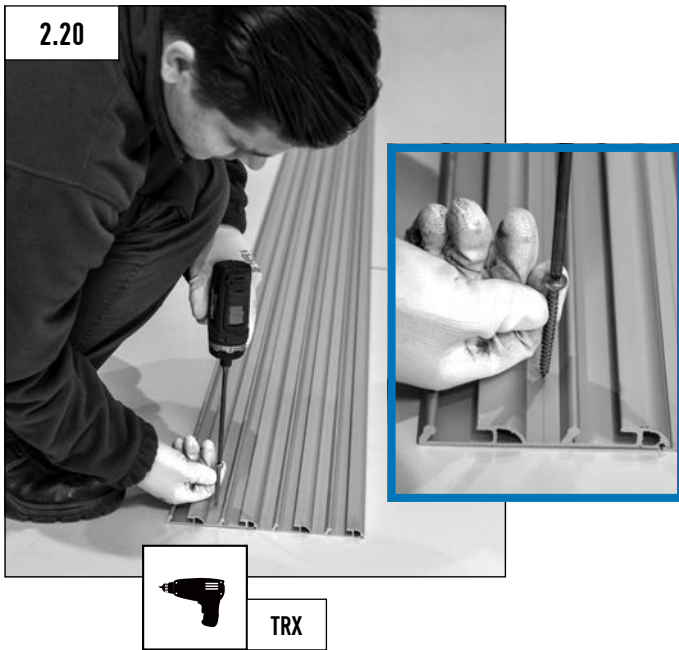
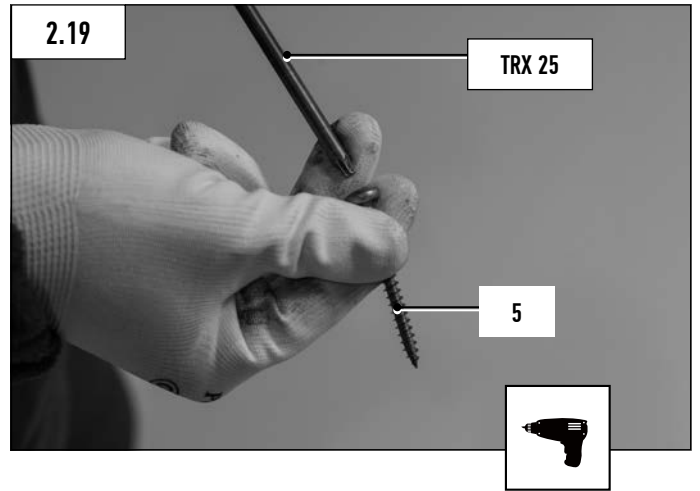

### 3 ASSEMBLAGE DU 1ER ÉLÉMENT

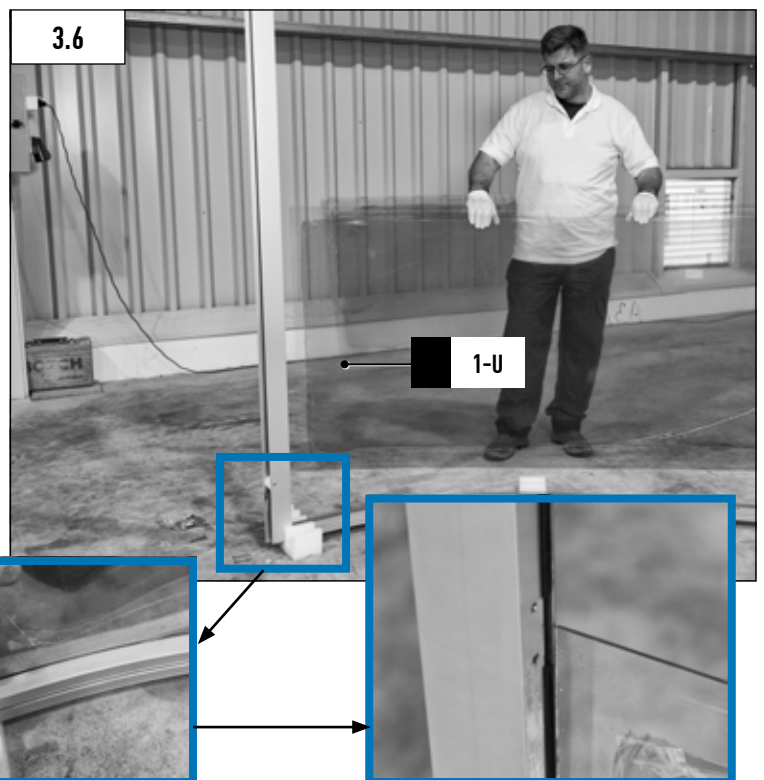
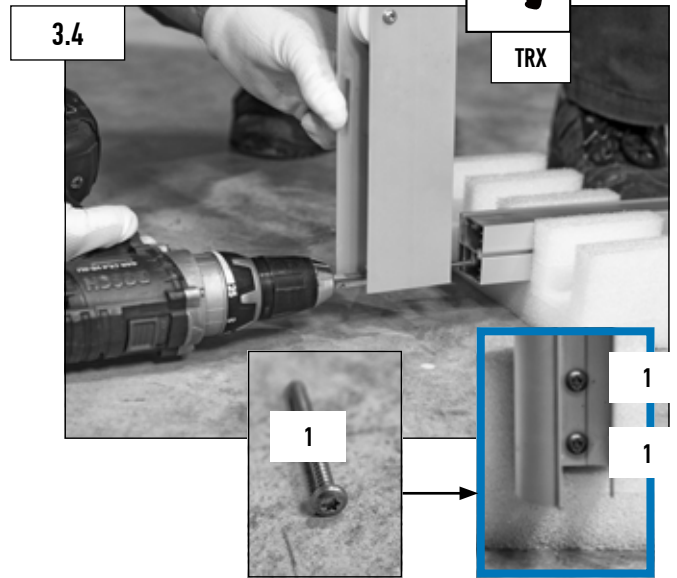
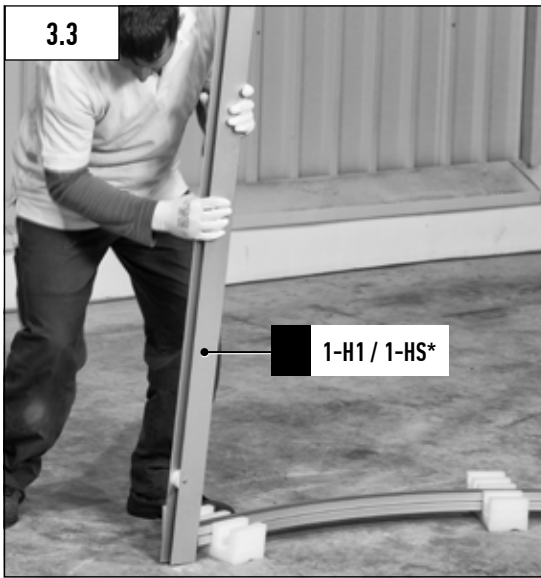
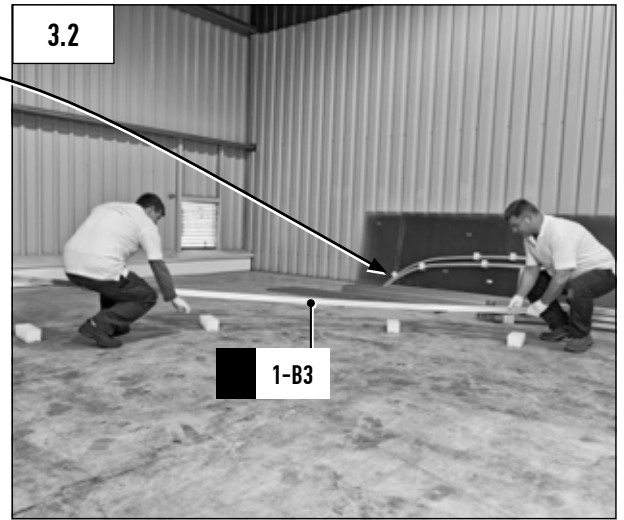
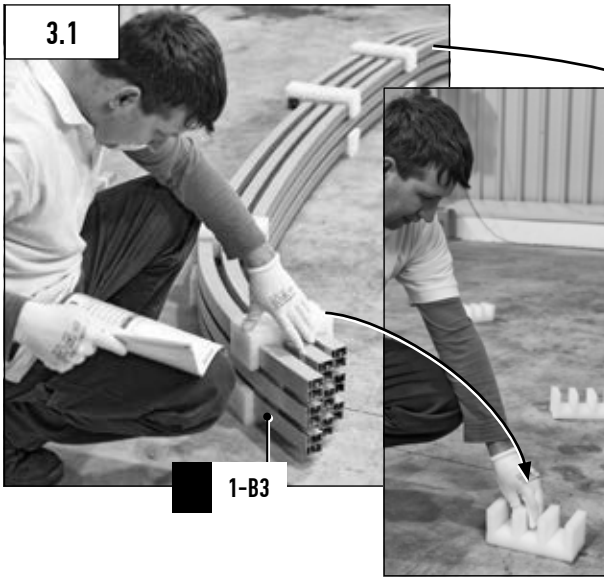

\* 1-HS =  
en cas de  
porte latérale  
coulissante

### 3 ASSEMBLAGE DU 1ER ÉLÉMENT

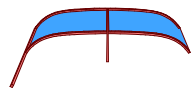
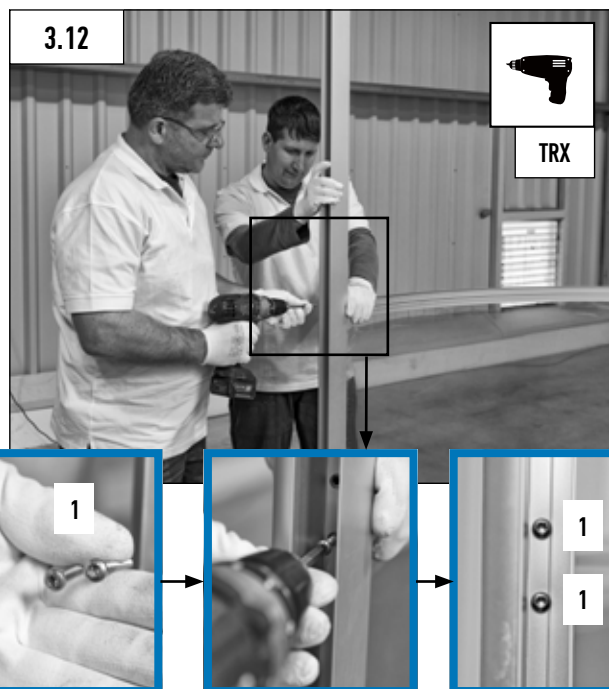
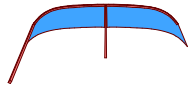
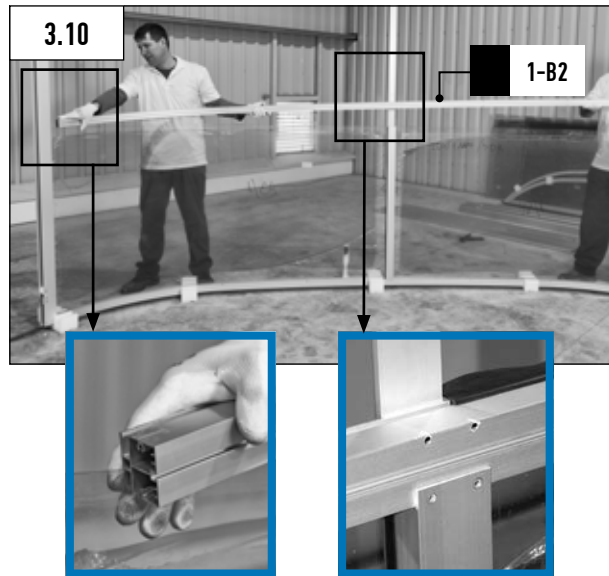
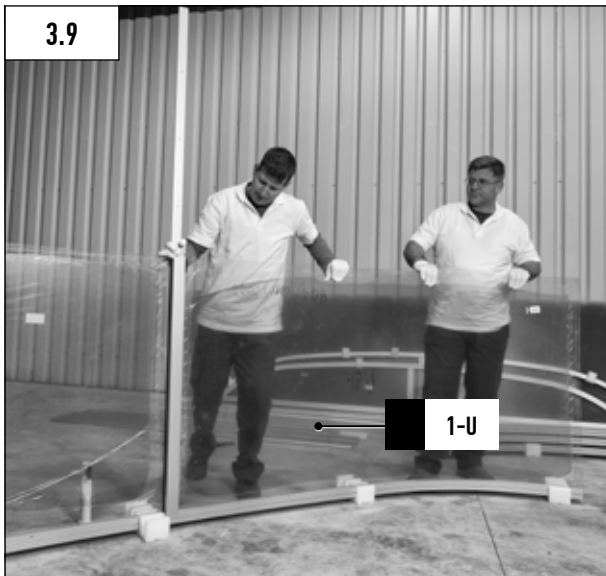
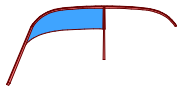
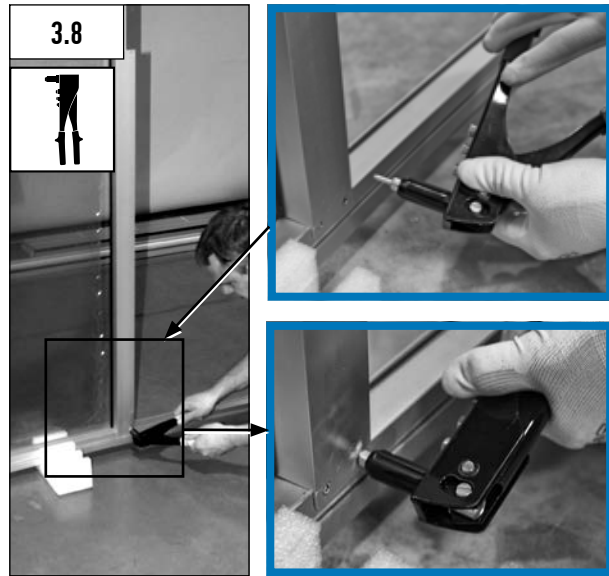
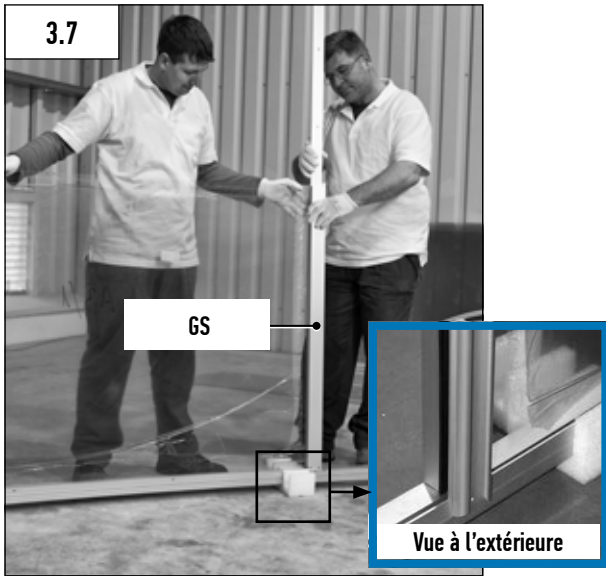

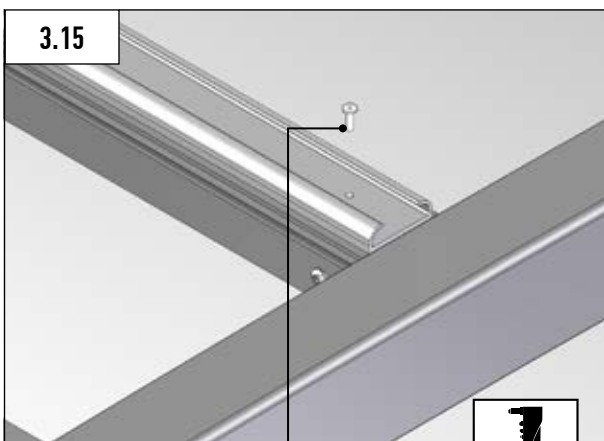
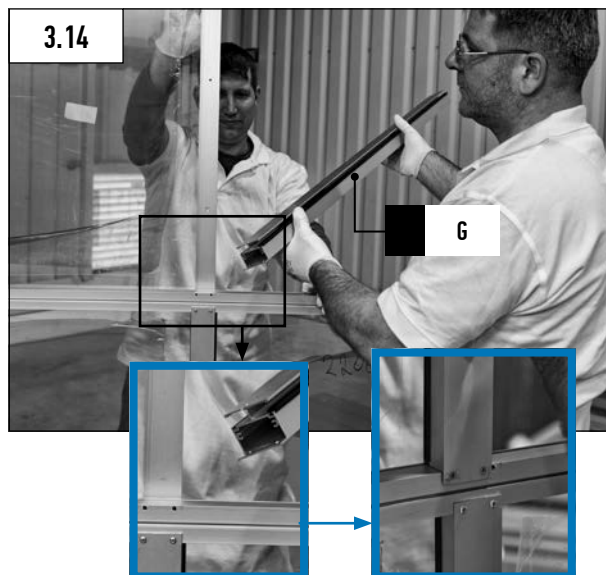
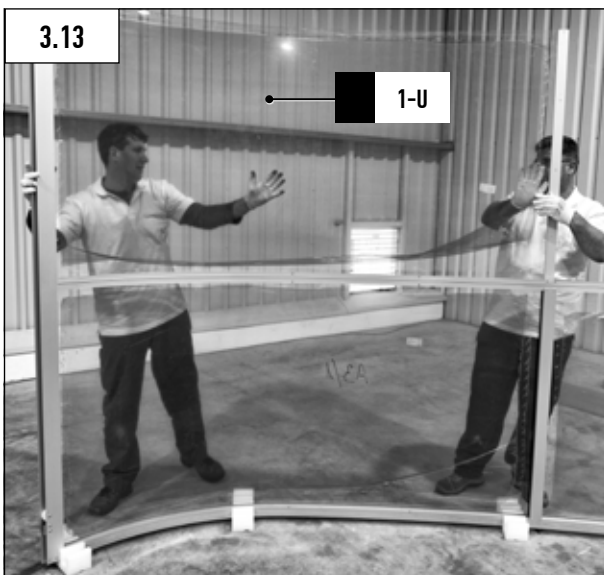
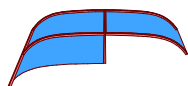

Merci de fixer la platine au profilé-G par les rivets de pop!

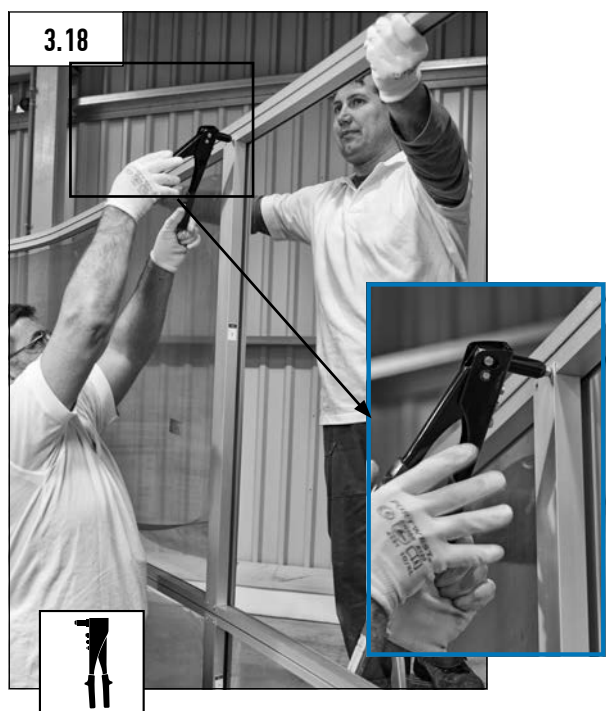
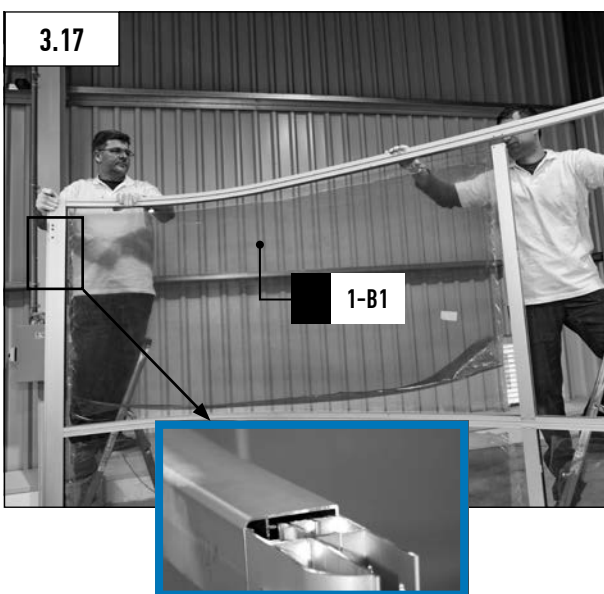

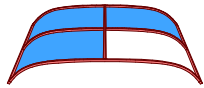
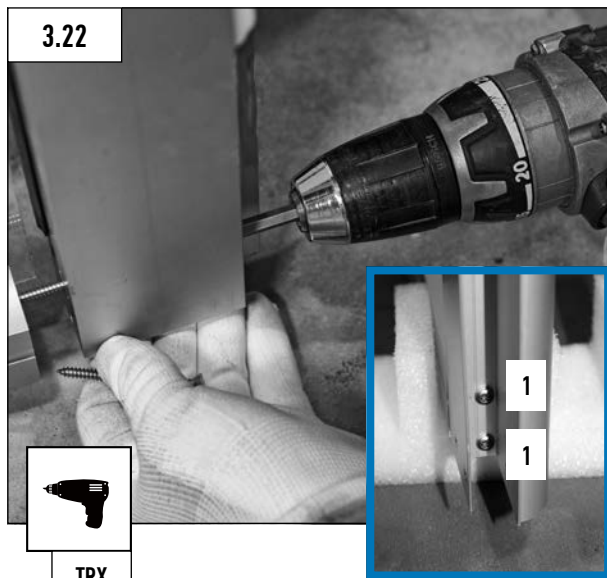
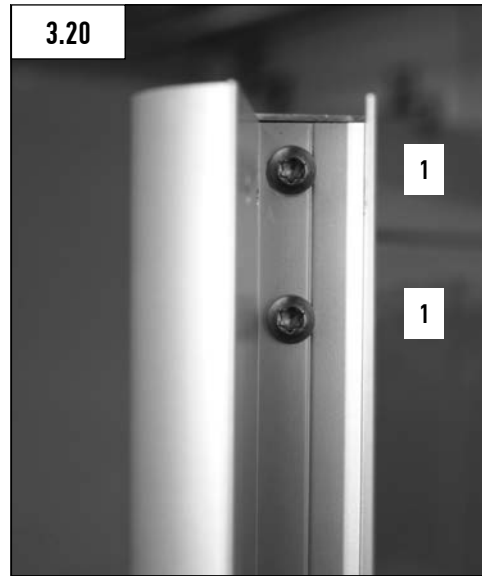
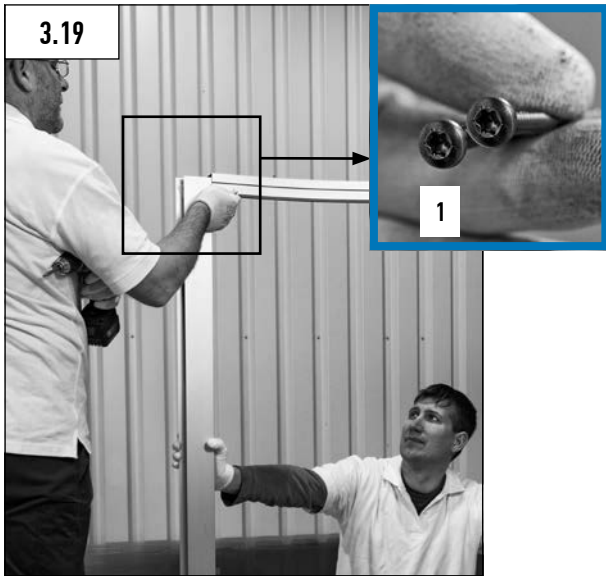

\* 1-HS =  
en cas de  
porte latérale  
coulissante

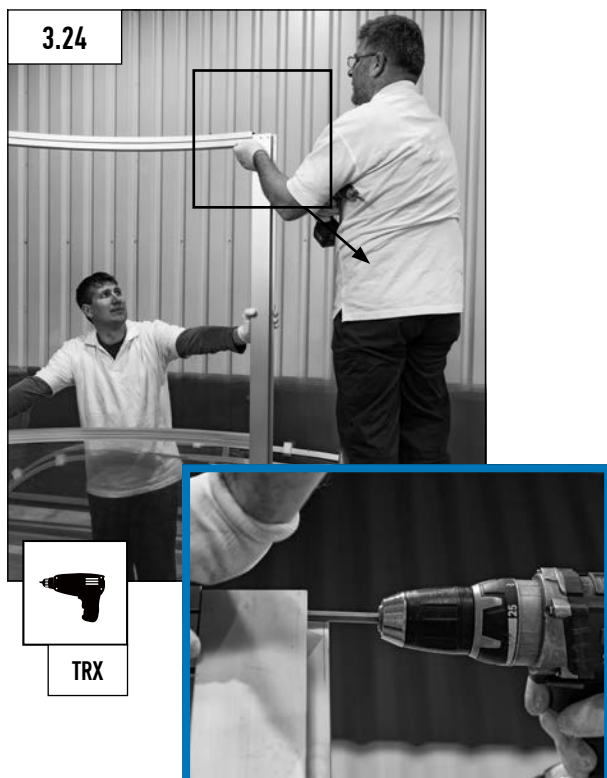

### 3 ASSEMBLAGE DU 1ER ÉLÉMENT

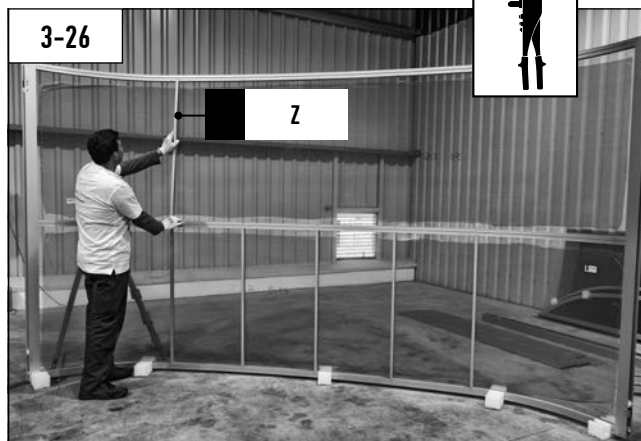

Plus d'informations sur le montage du profilé Z, page 34 images 4.17 - 4.18.

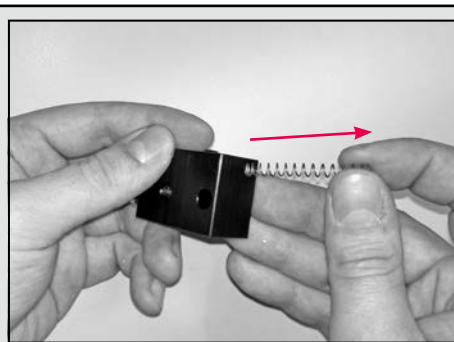
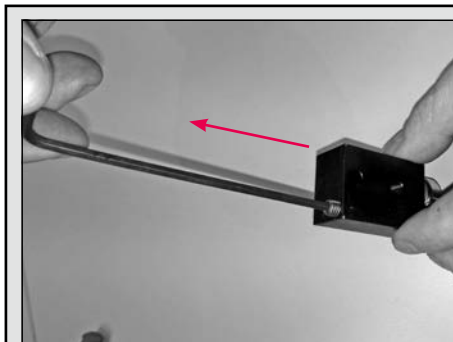

**Option:**  
Déboulonner le vis, enlever le ressort, l'élément sera verrouillé et fermé automatiquement. L'autre coté doit rester avec verrouillage manuel. (Ne pas enlever le ressort).

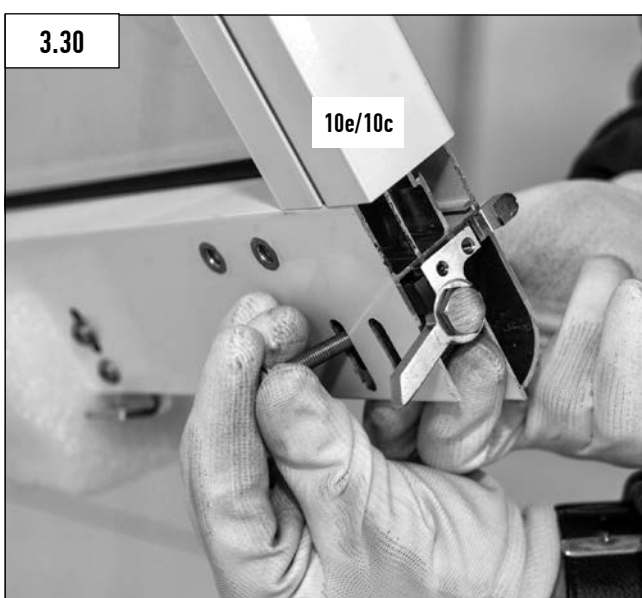
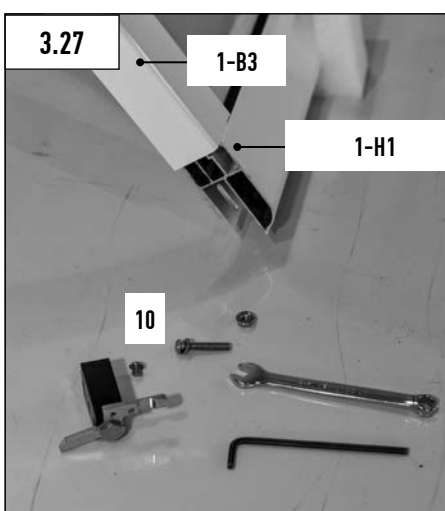

### 3 ASSEMBLAGE DU 1ER ÉLÉMENT

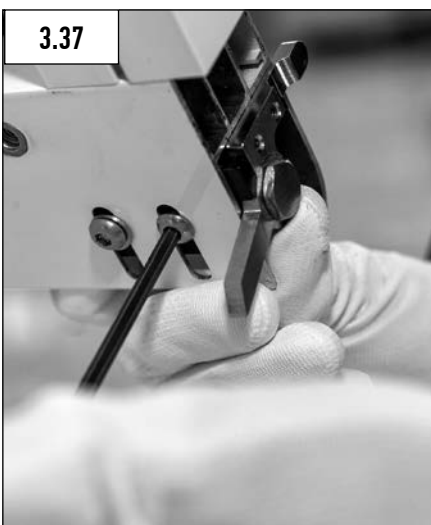
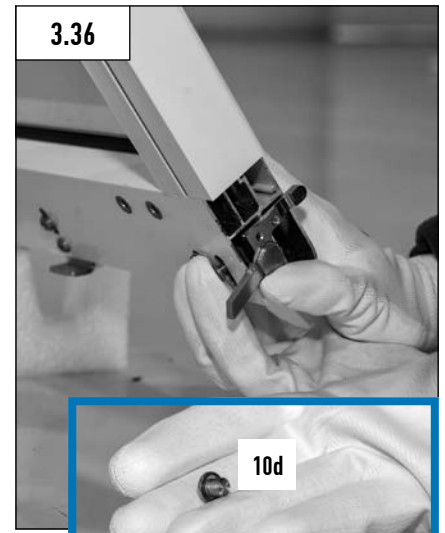

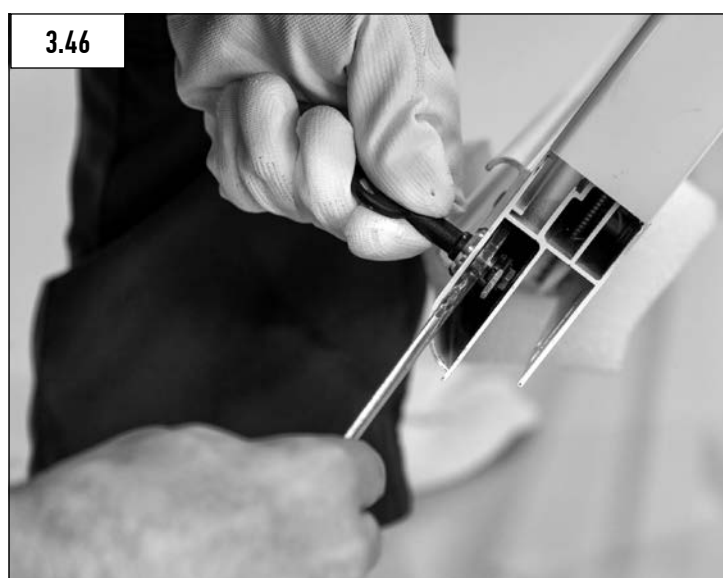
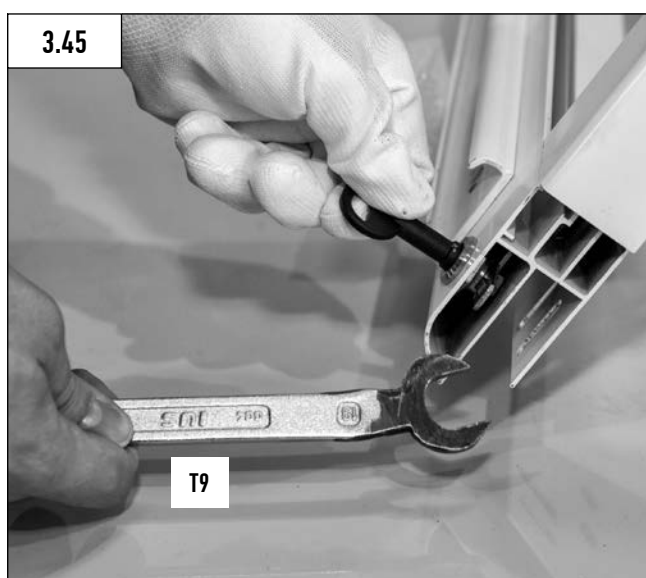
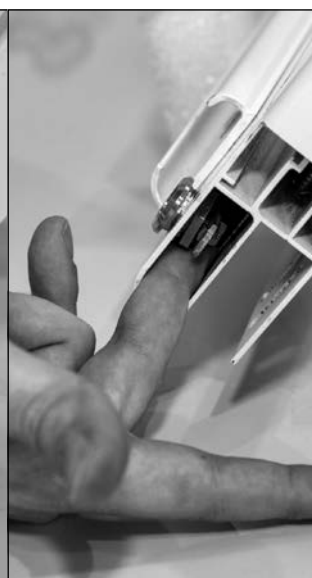
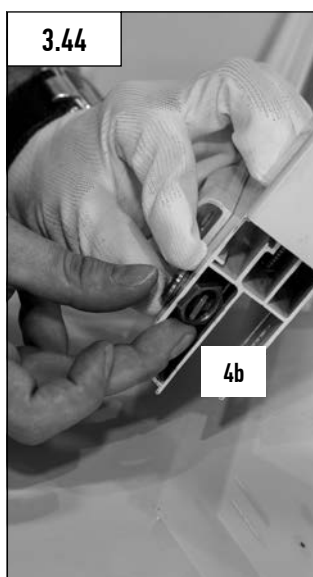
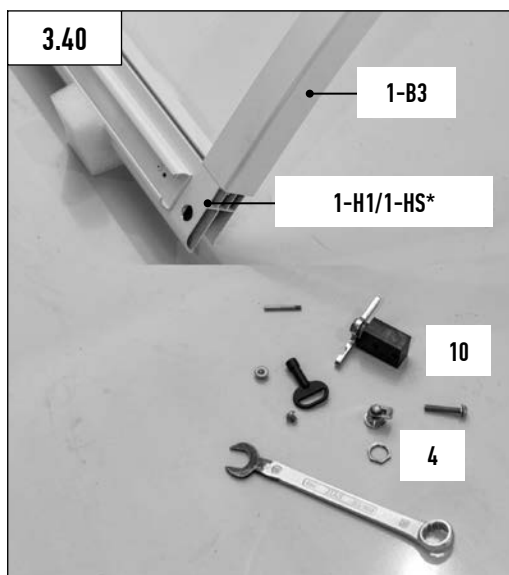



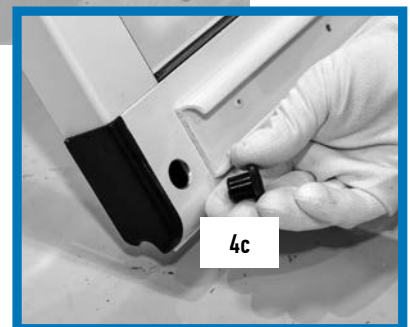
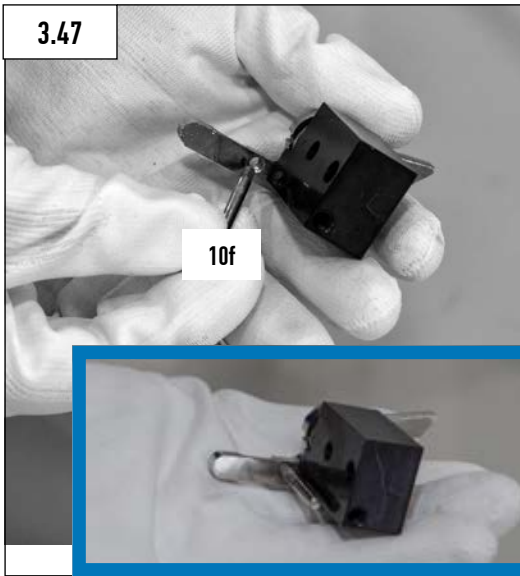

# 4 ASSEMBLAGE DE L'ÉLÉMENT INTERMÉDIAIRE

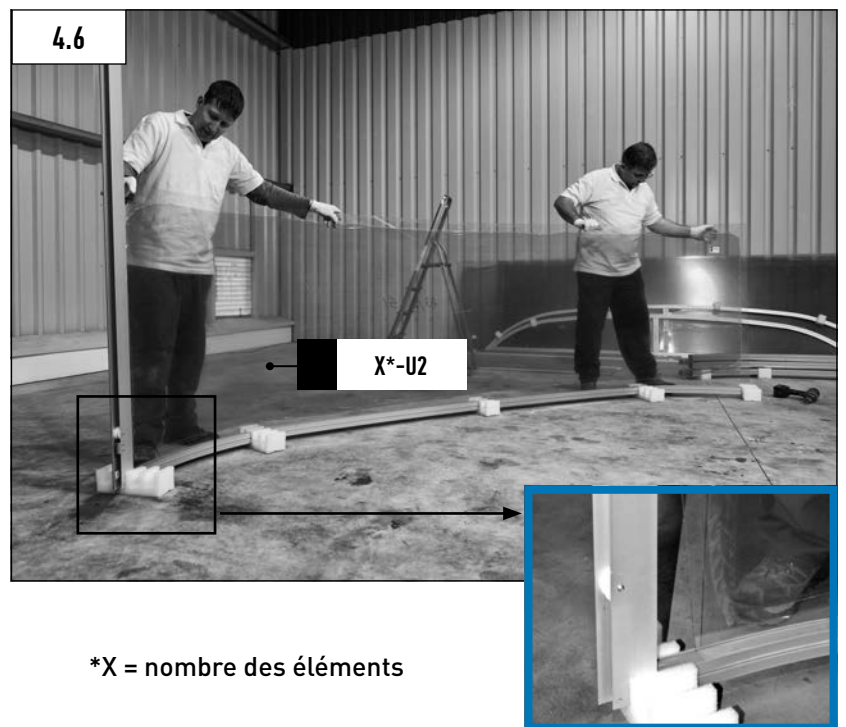
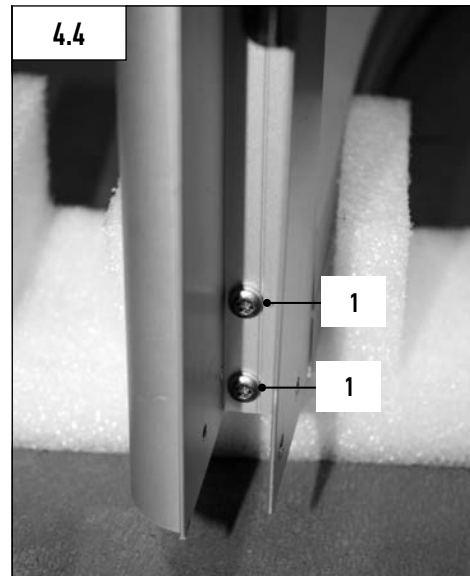
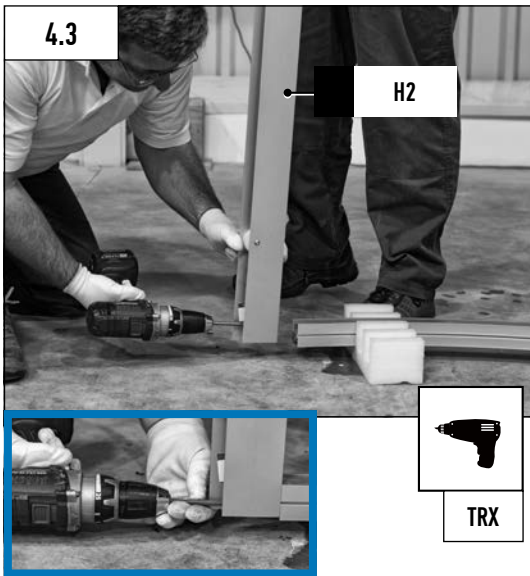
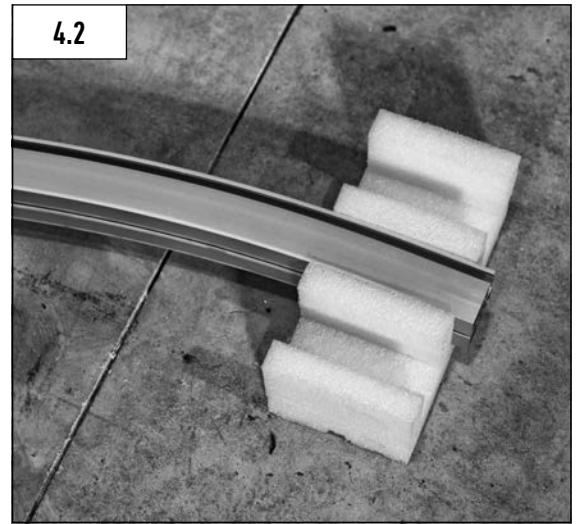
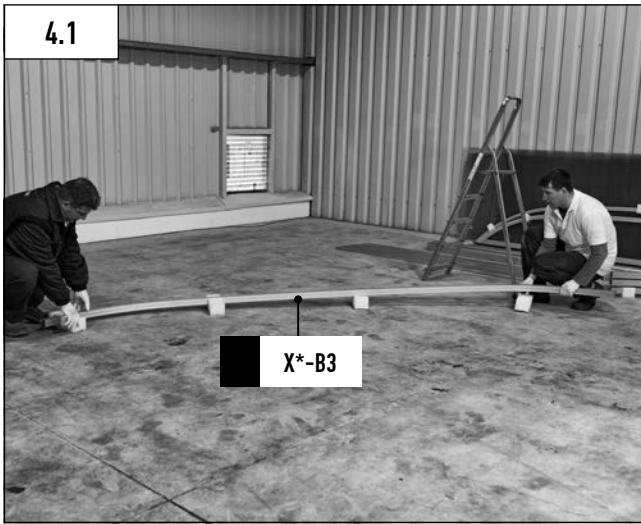

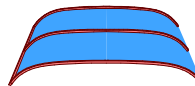
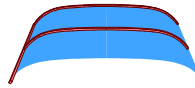
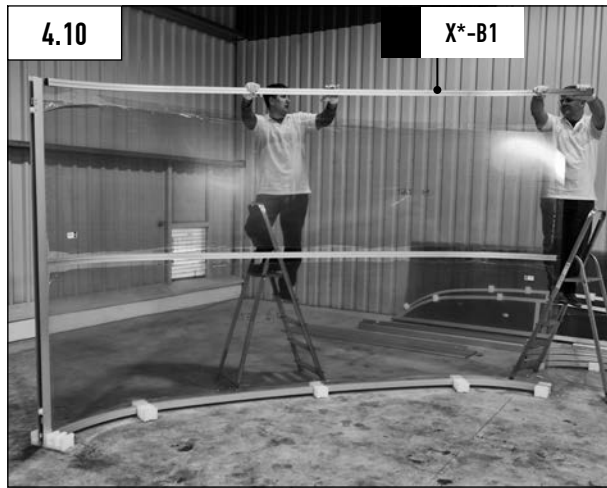
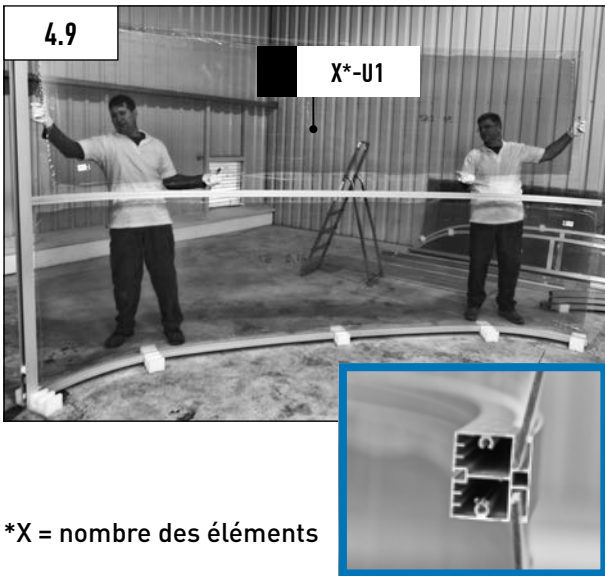
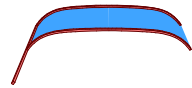
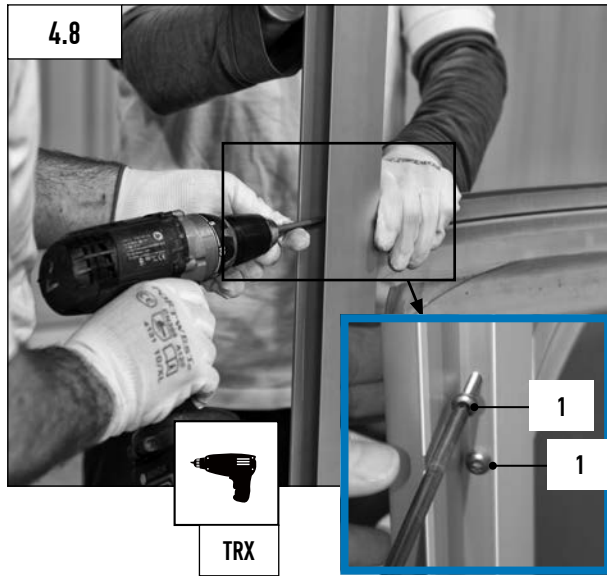
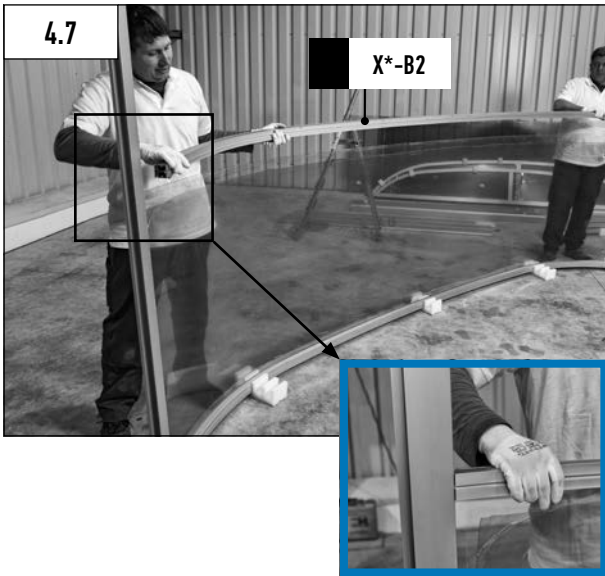

\*X = nombre des éléments

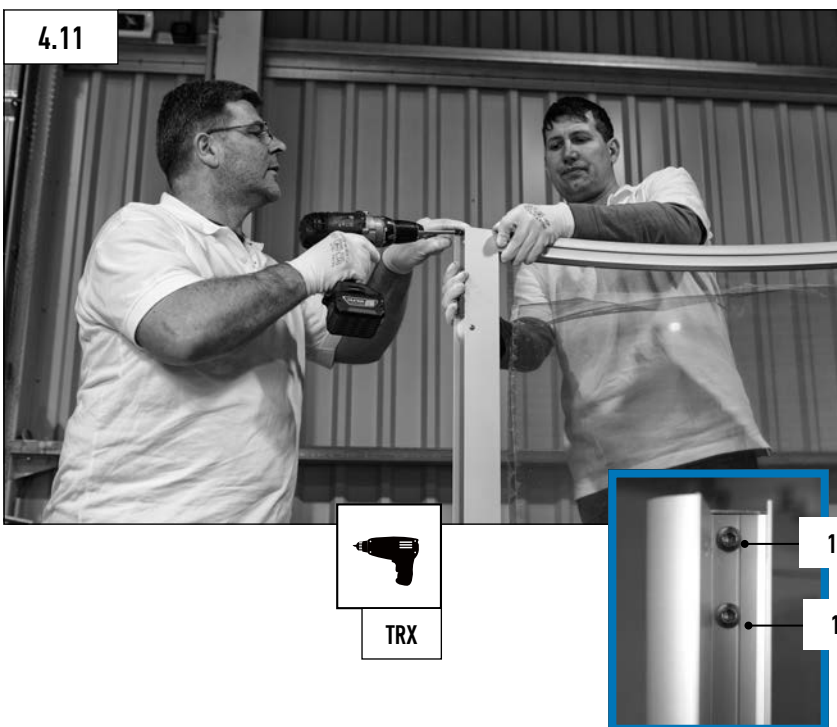

# 4 ASSEMBLAGE DE L'ÉLÉMENT INTERMÉDIAIRE

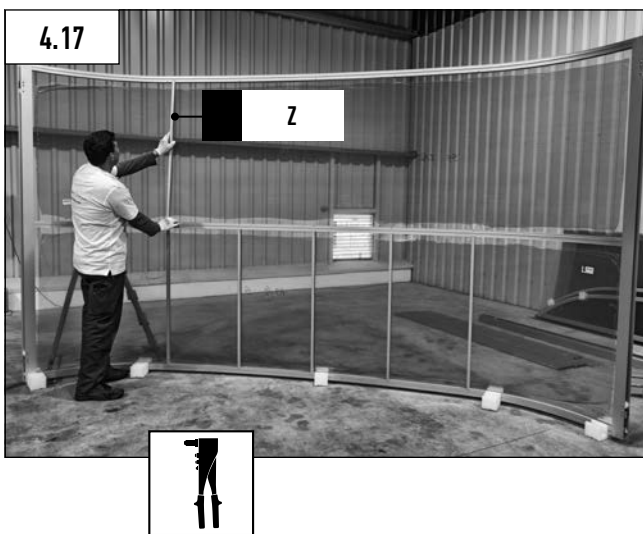
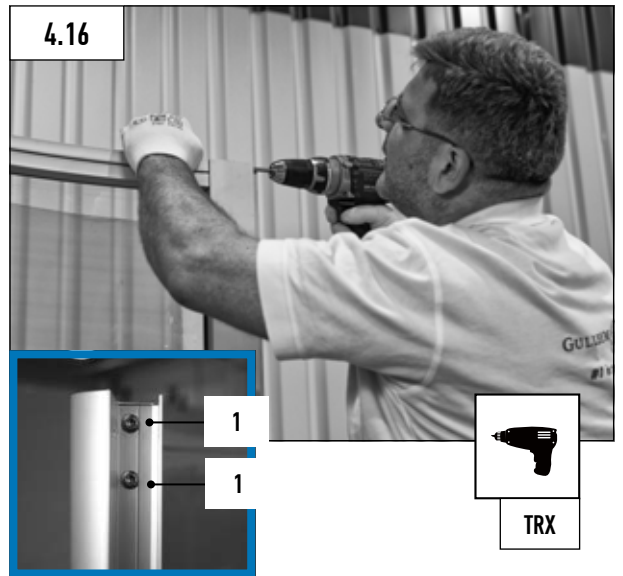
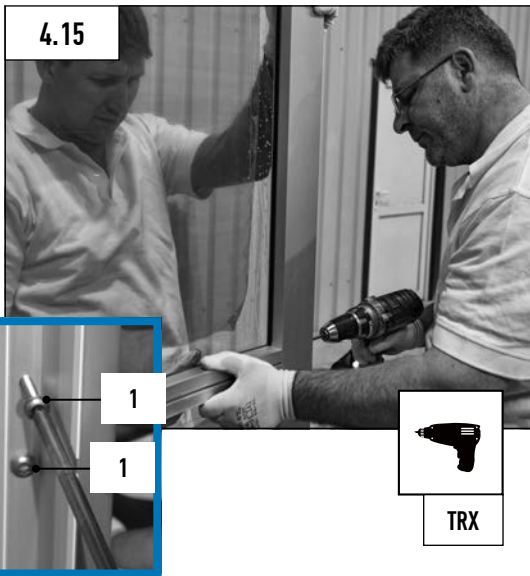
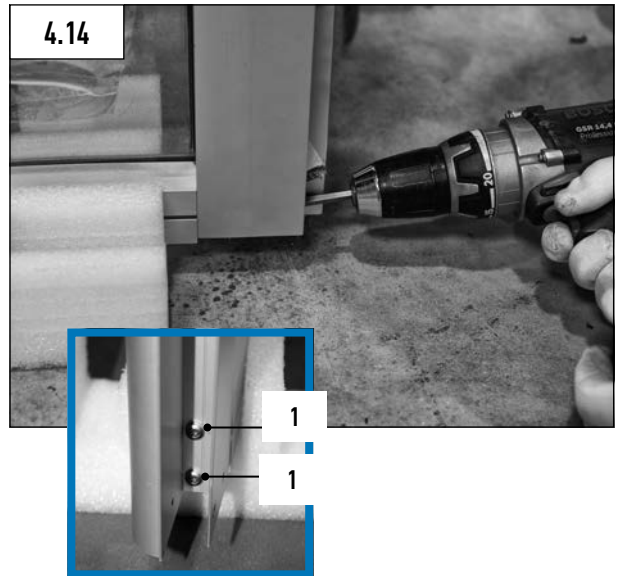

\*X = nombre des éléments

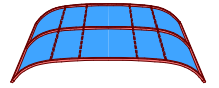
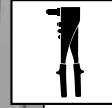

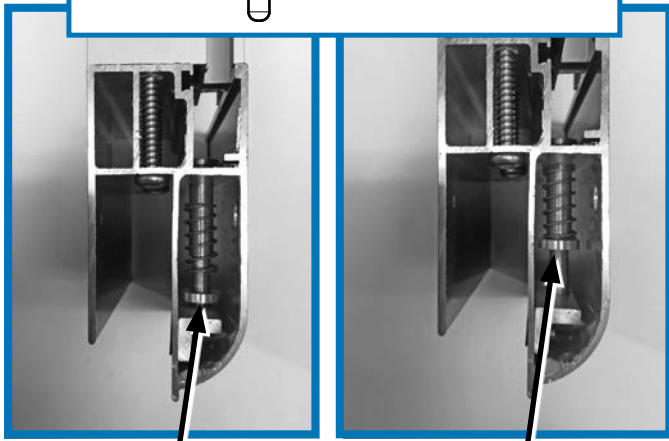
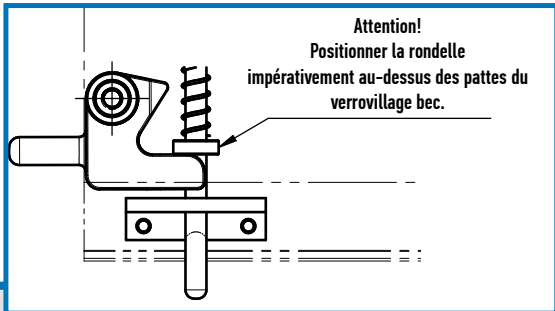
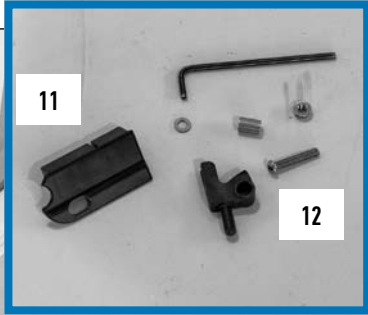

Fautif

Correct

Vérifier la position de la rondelle!

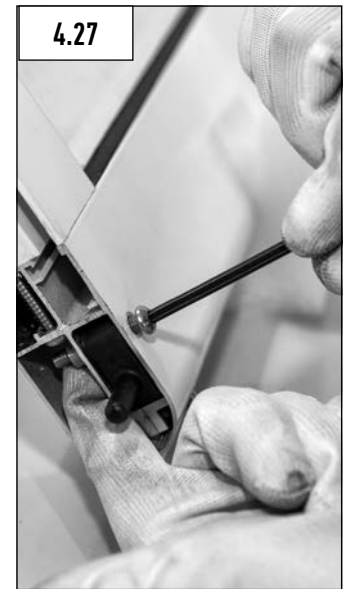
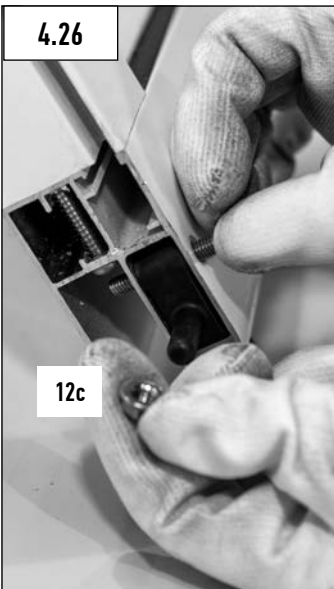
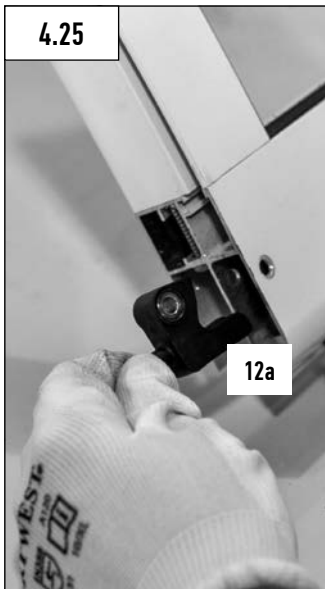

4.28

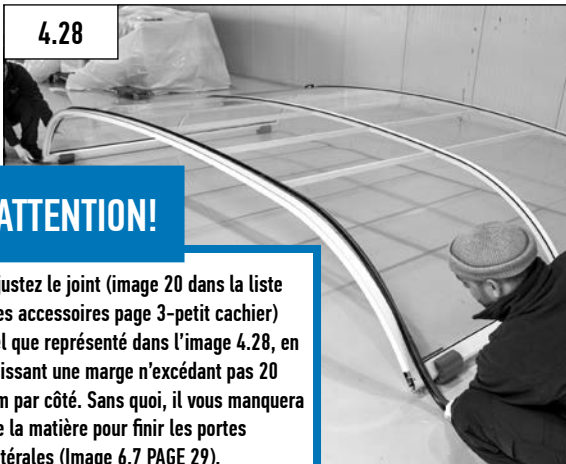
**ATTENTION!**

Ajustez le joint (image 20 dans la liste des accessoires page 3-petit cachier) tel que représenté dans l'image 4.28, en laissant une marge n'excédant pas 20 cm par côté. Sans quoi, il vous manquera de la matière pour finir les portes latérales (Image 6,7 PAGE 29).

4.29



4.30



4.31

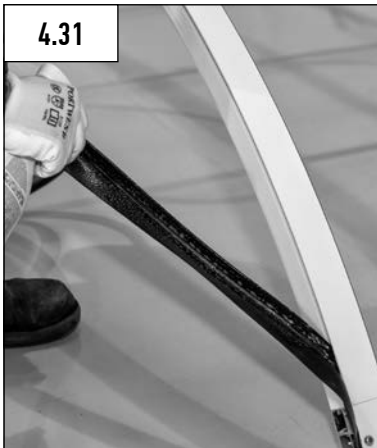

4.32



4.33



4.34



4.35



4.36



4.37



4.38



4.39



4.40

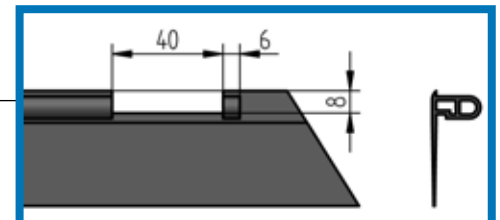

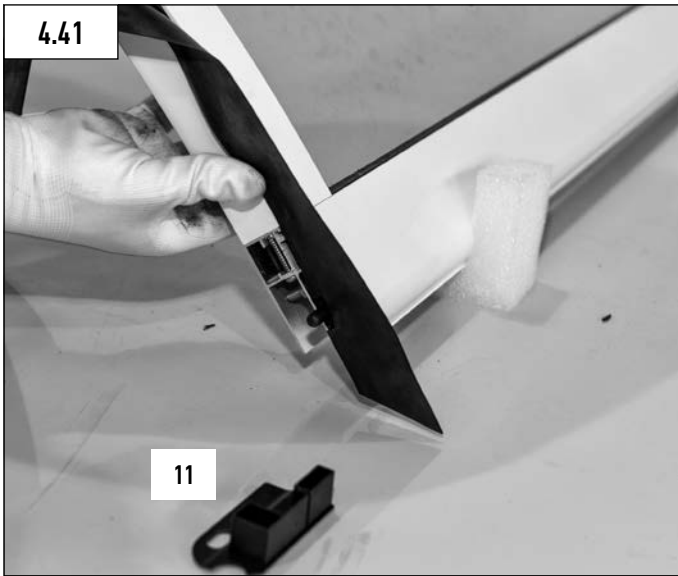

**Répéter les démarches  
4.1-4.47  
(voir page 30-36)**



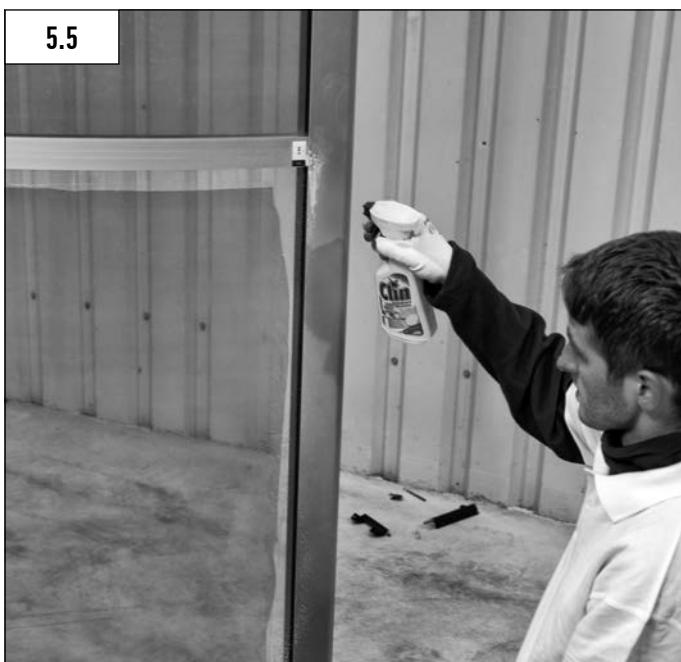
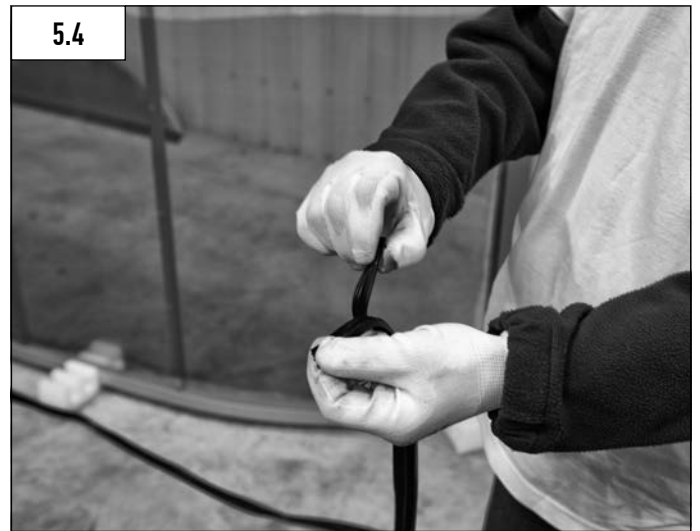



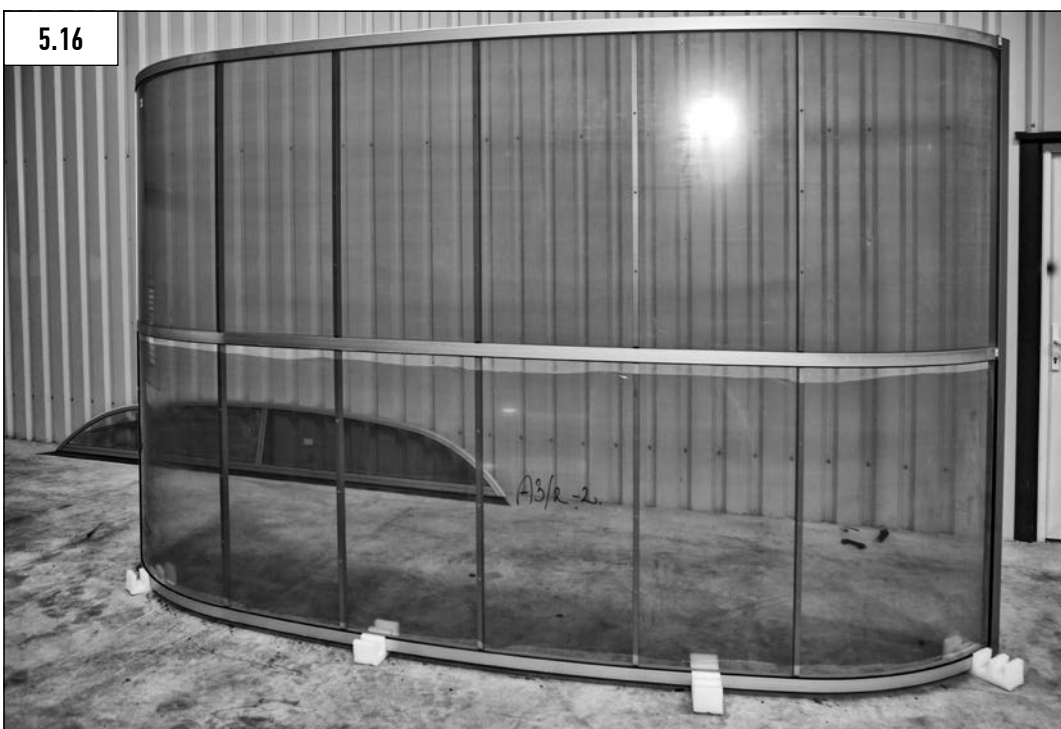

# 6 ASSEMBLAGE DE PORTE LATÉRALE COULISSANTE

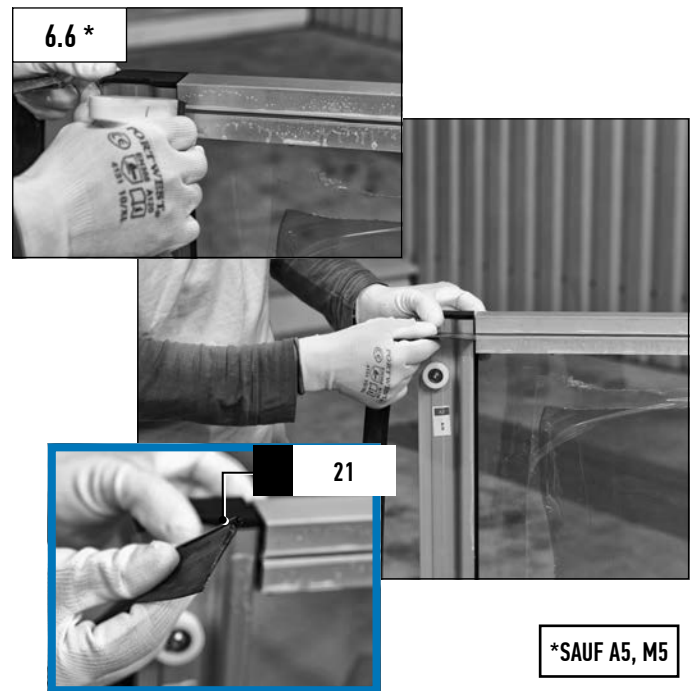
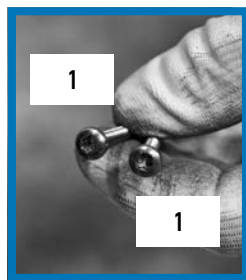
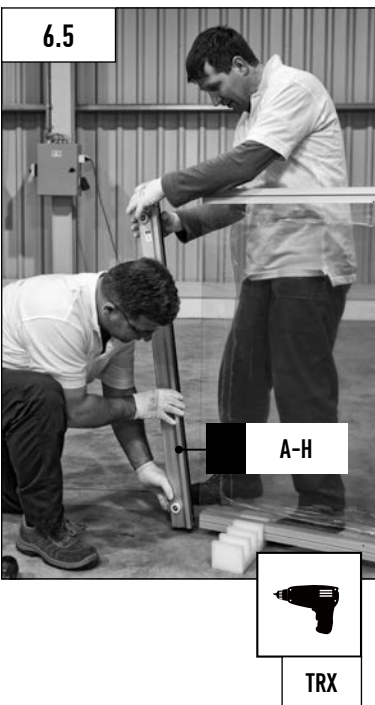
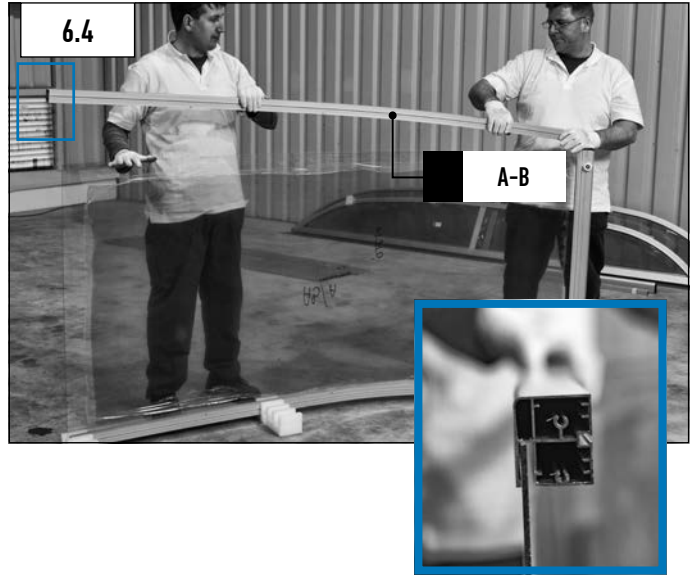
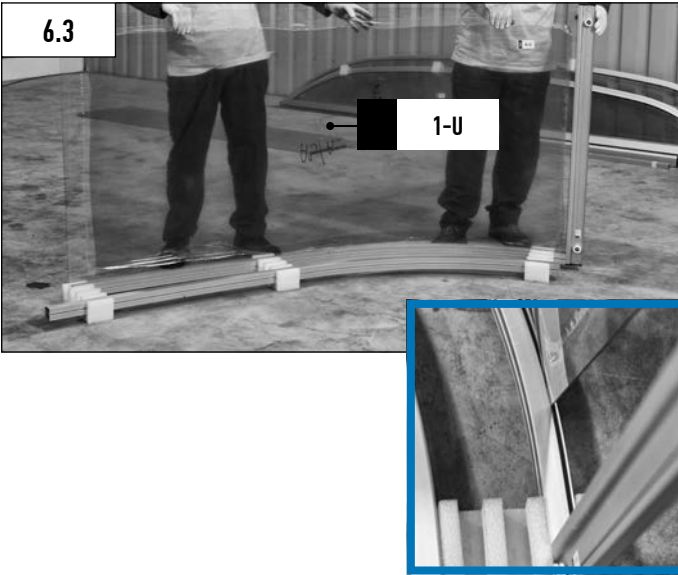
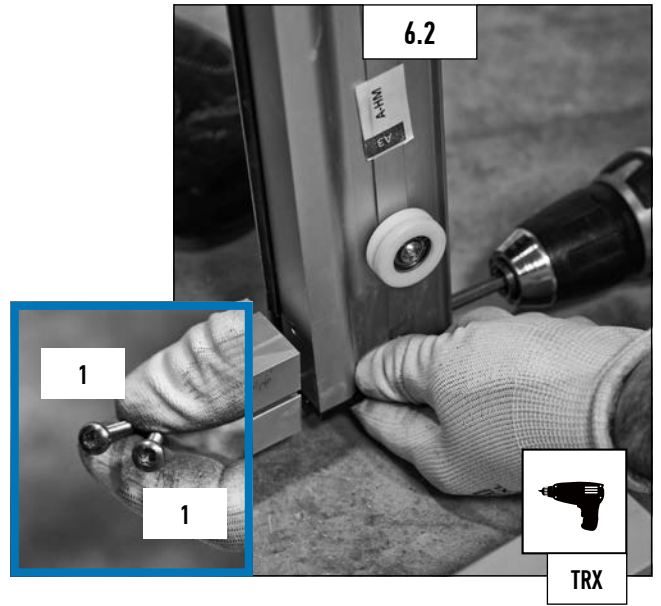
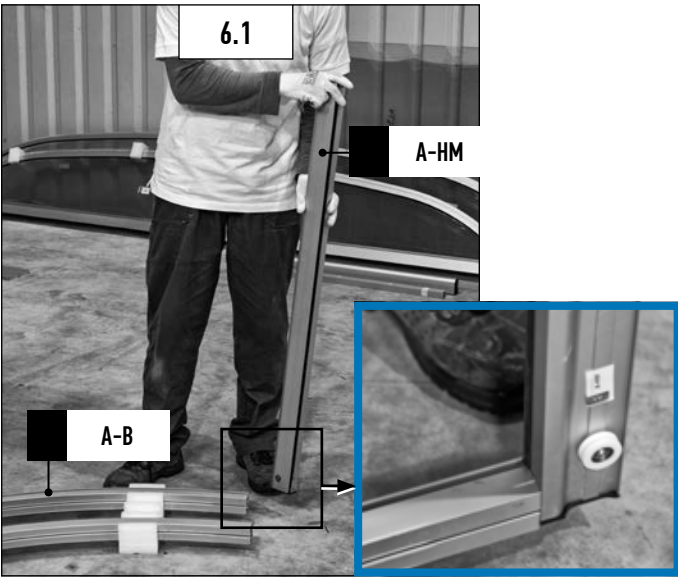

# 6 ASSEMBLAGE DE PORTE LATÉRALE COULISSANTE



6.7\*

\*SAUF. A5, M5



TRX



6.8



TRX

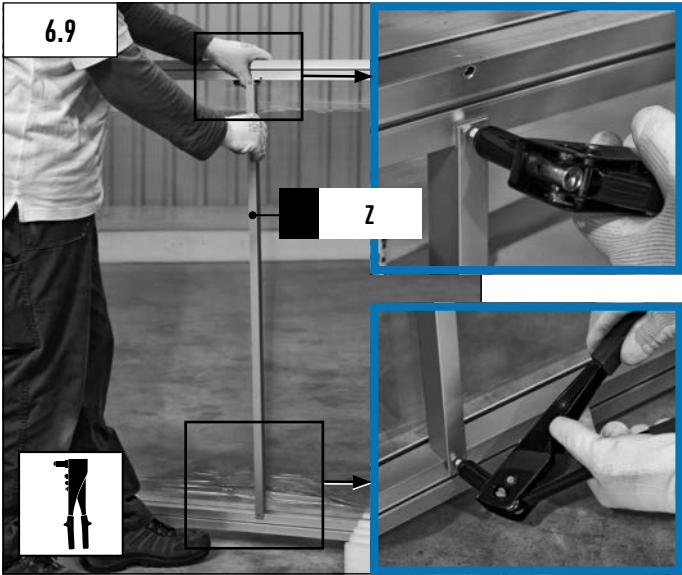

6.9

Z



6.10

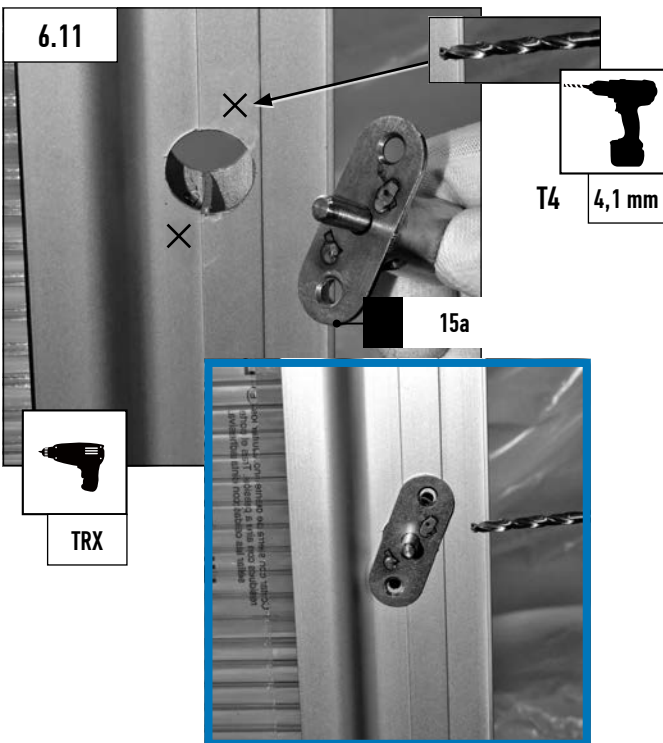

6.11

T4 4,1 mm

15a



TRX

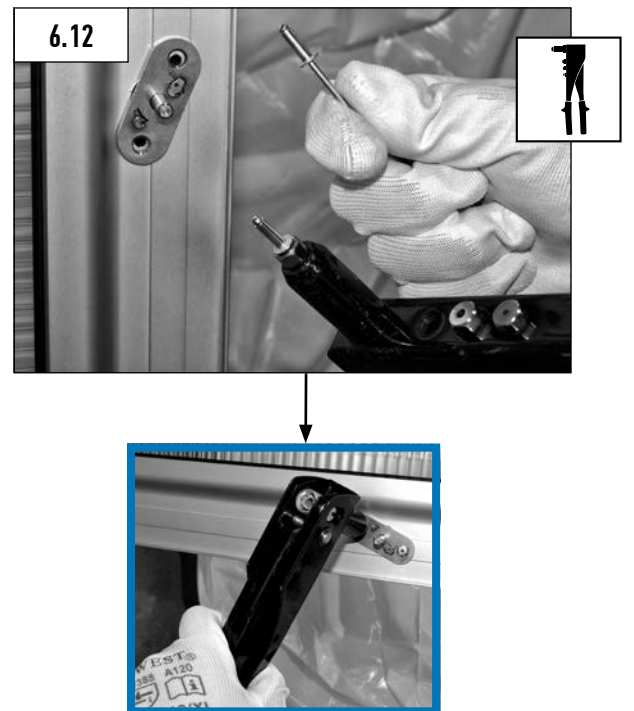

6.12

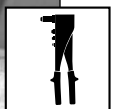

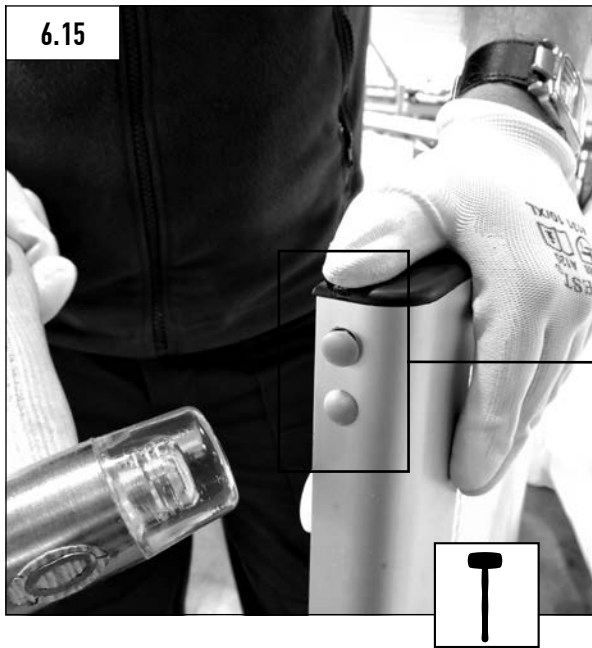
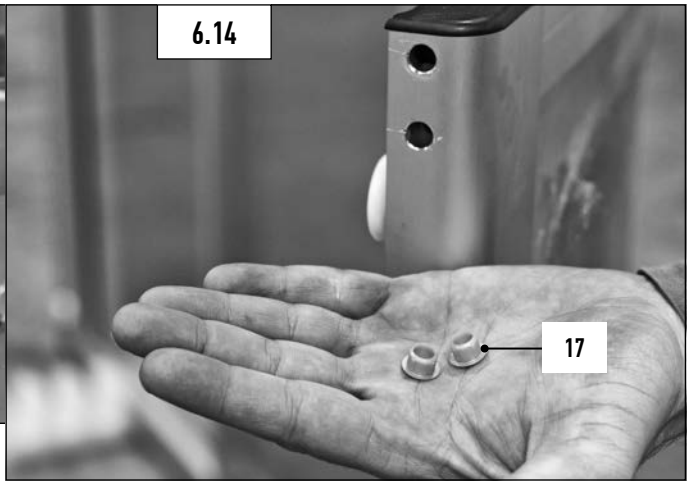

# 6 POSE DU JOINT – PORTE LATÉRALE COULISSANTE (JOINT INTÉRIEUR ET EXTÉRIEUR DE POLYCARBONATE PLEIN)

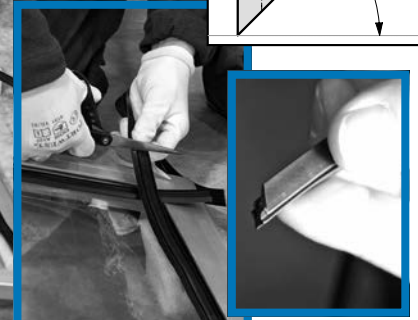
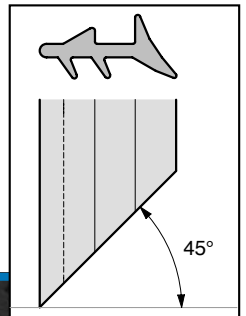
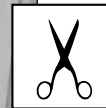
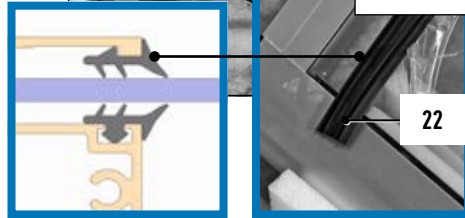
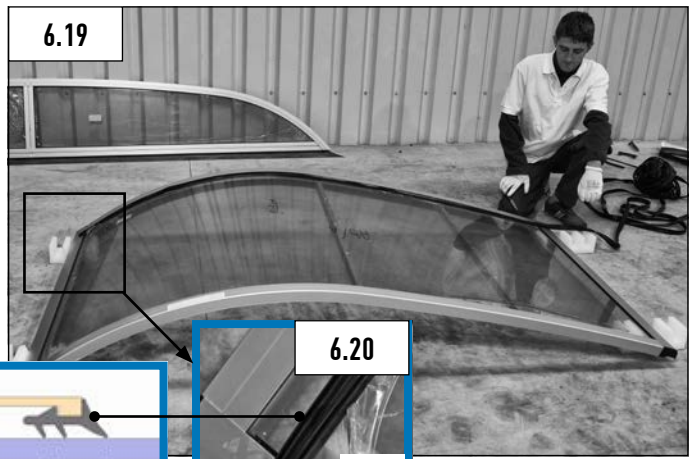
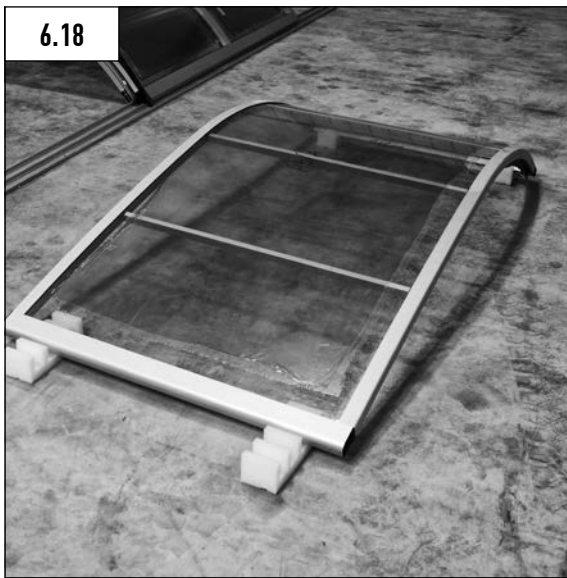

## 6 POSE DU JOINT – PORTE LATÉRALE COULISSANTE (JOINT INTÉRIEUR ET EXTÉRIEUR DE POLYCARBONATE PLEIN)

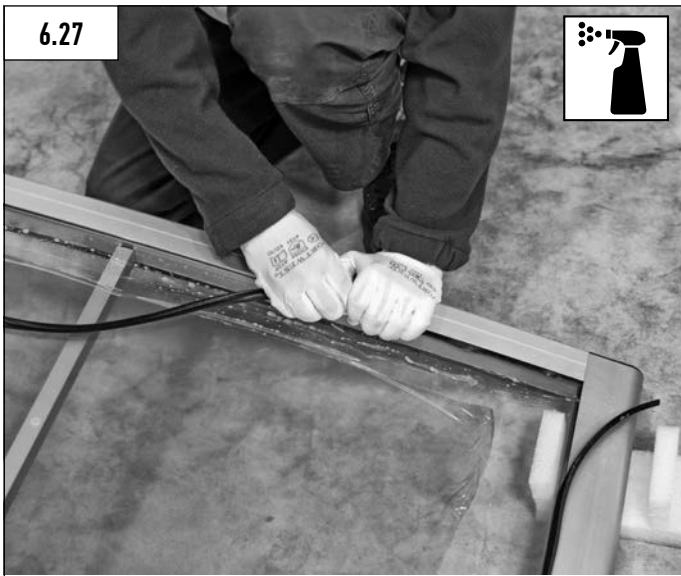
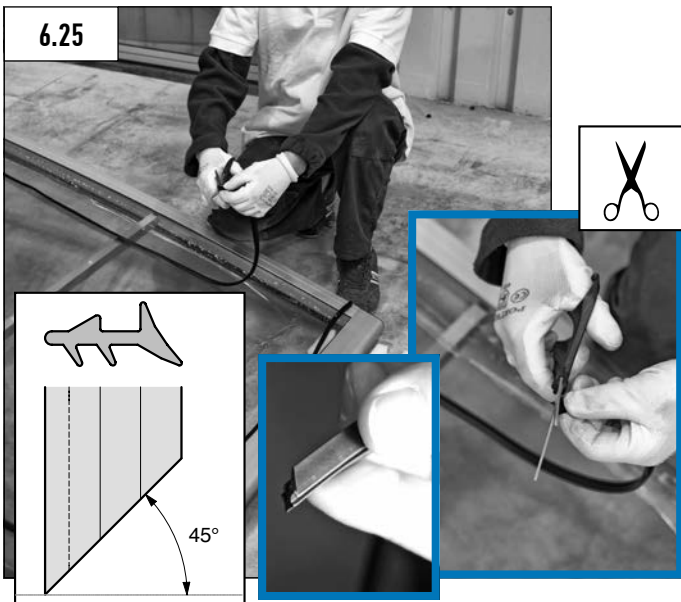



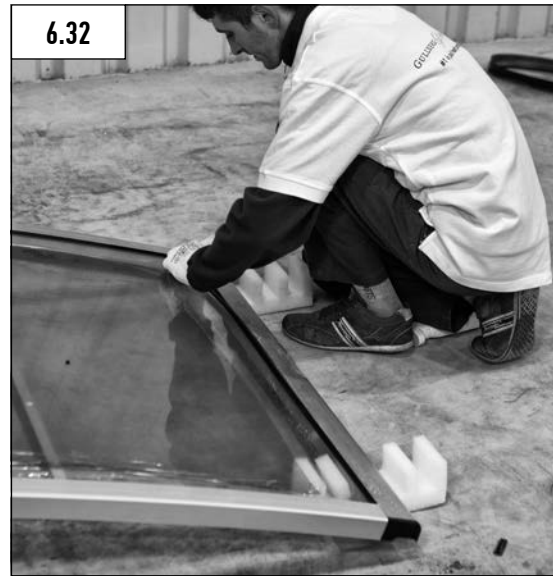

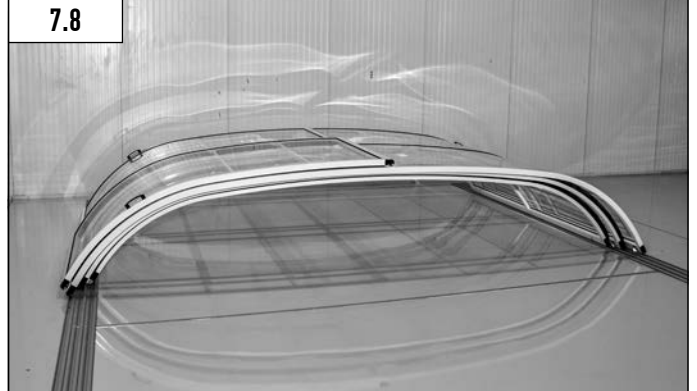
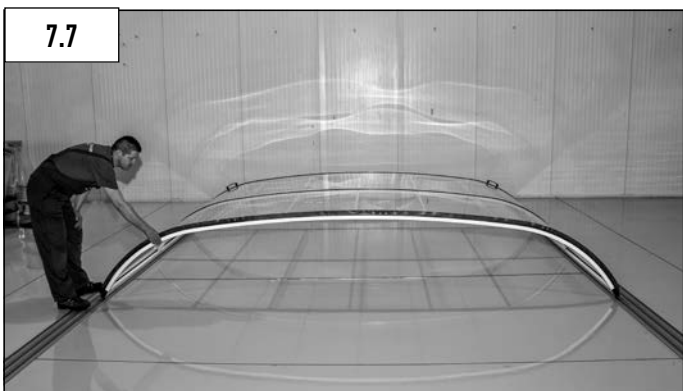
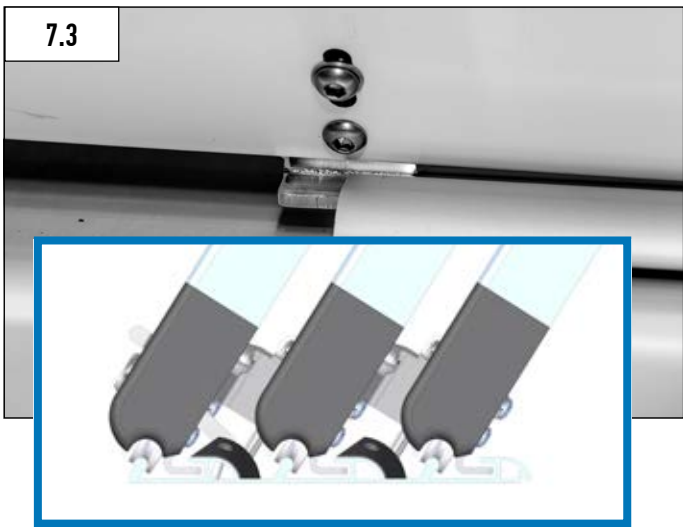
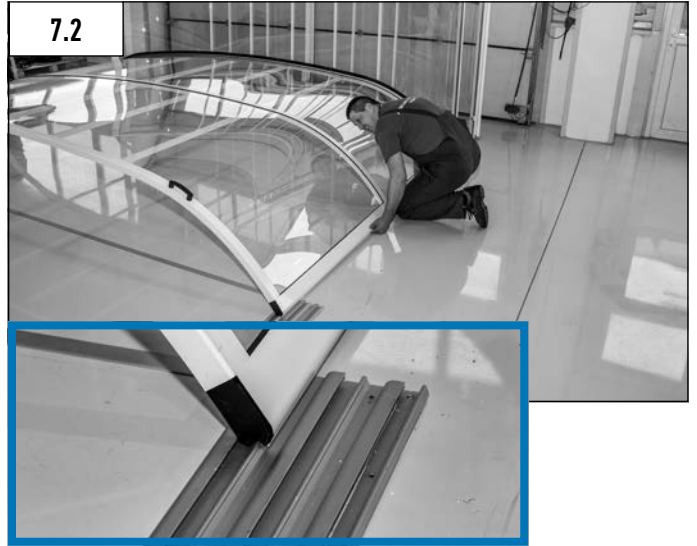

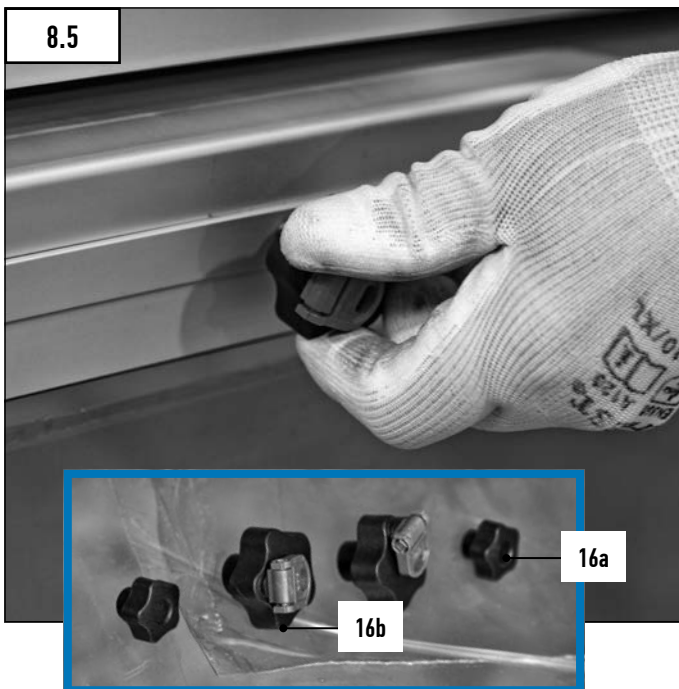
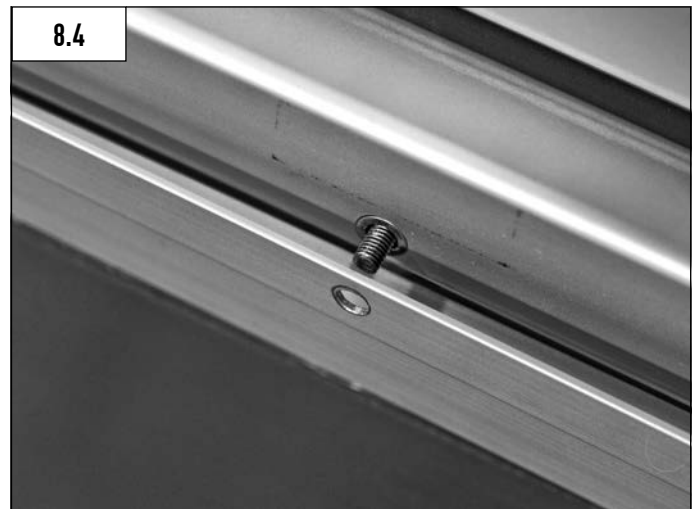

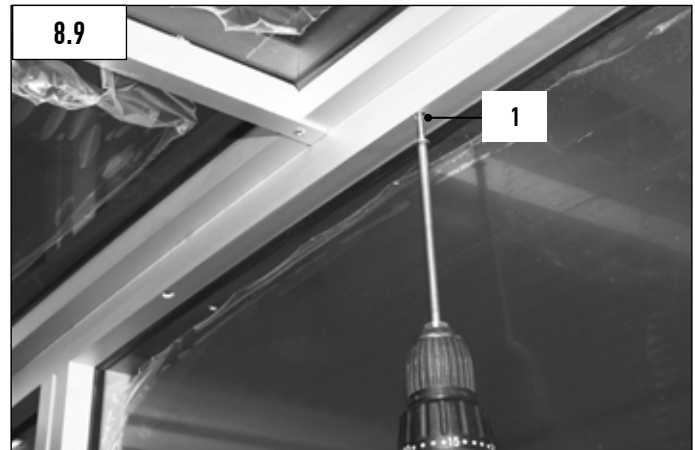
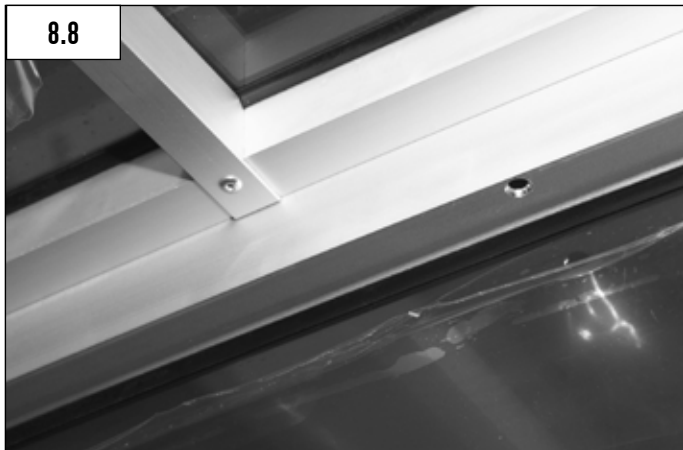

**pour les modèles A5 - M5**

**Visser graduellement en commençant du haut vers le bas  
pour que la façade et le fond se mettent  
en place sans forcer.**

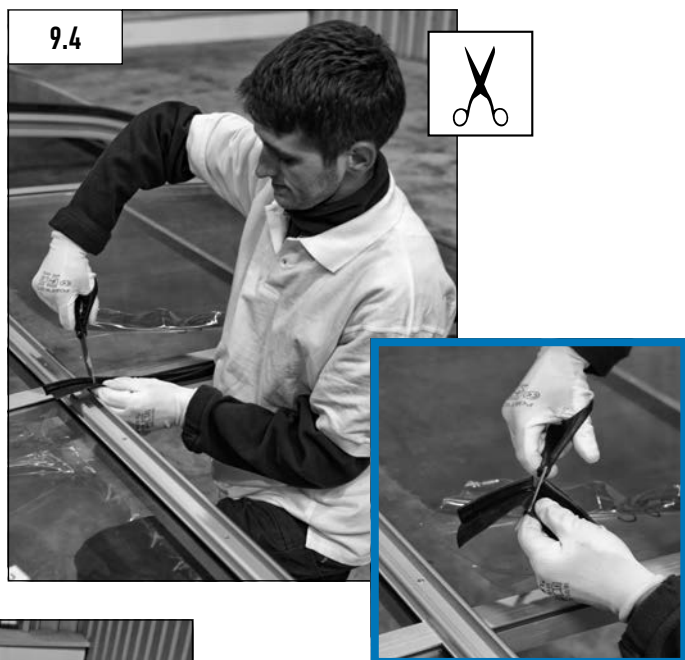
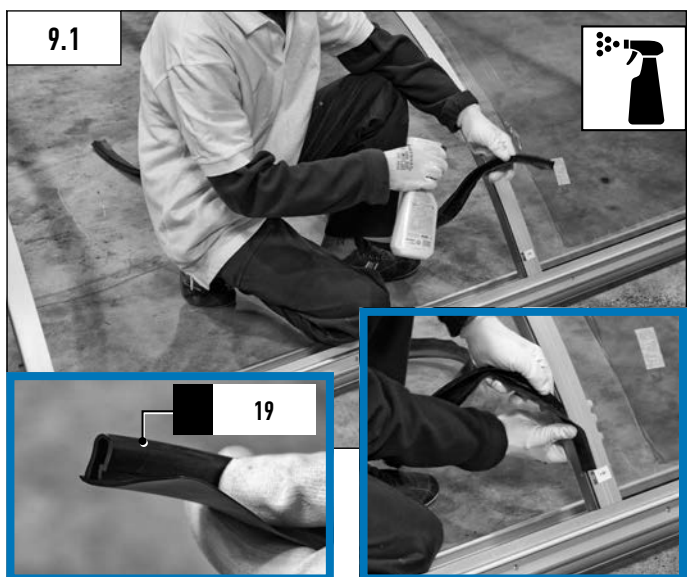

**Avec des modèles**  
**A3 - A3/4 - A4S - A4L - A4 - A4/5 - M3 - M4 - M4/5**

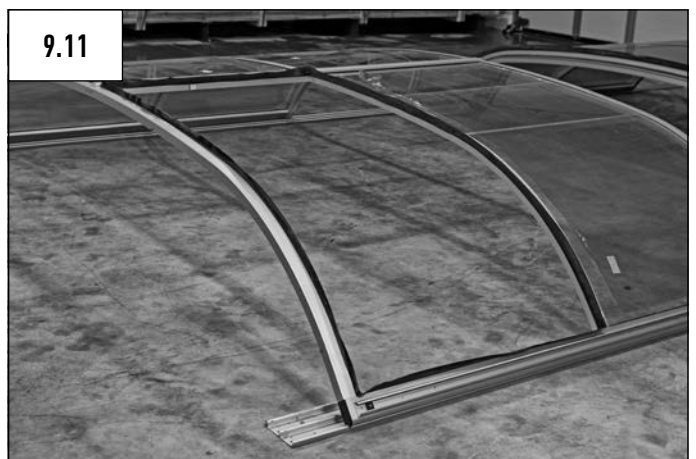
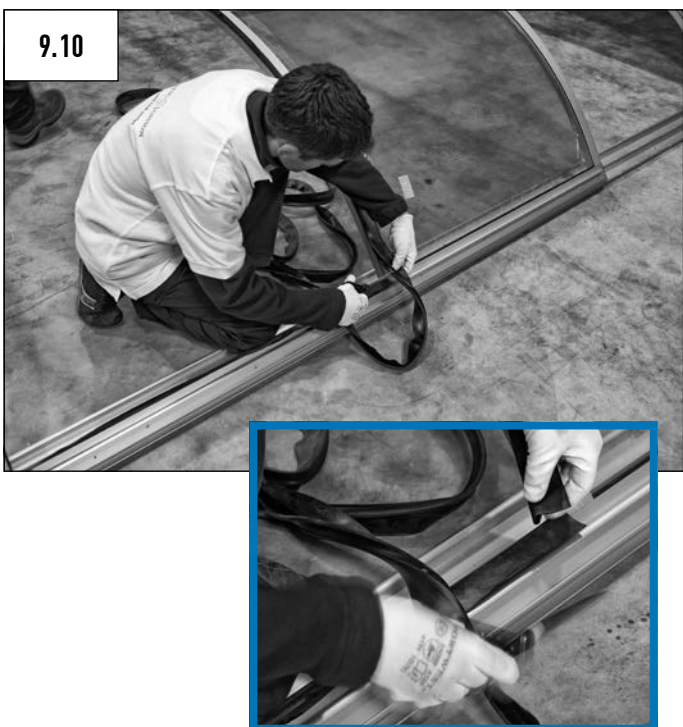
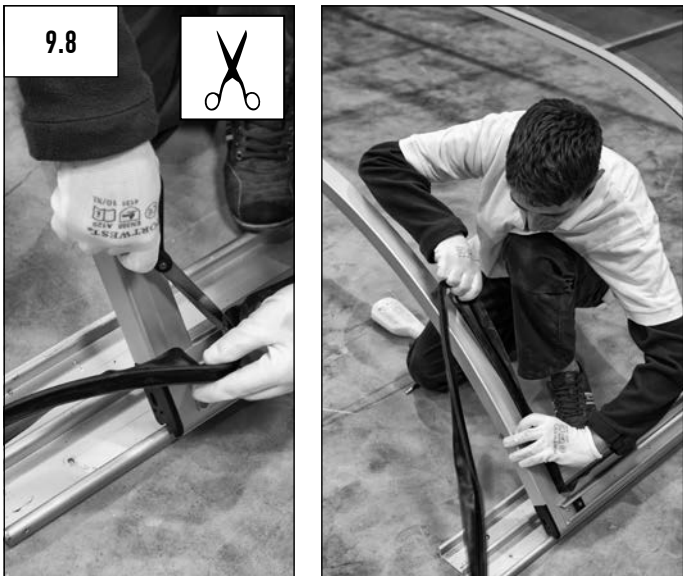
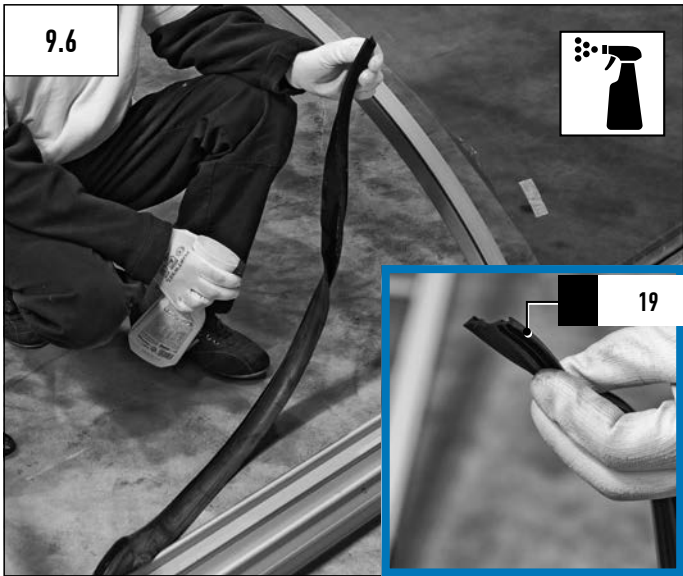

Avec modèles A5 - M5

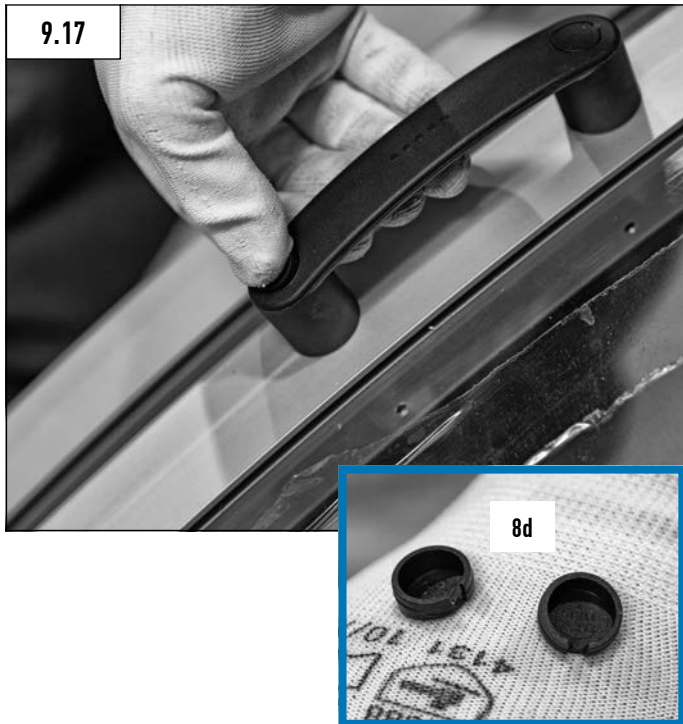
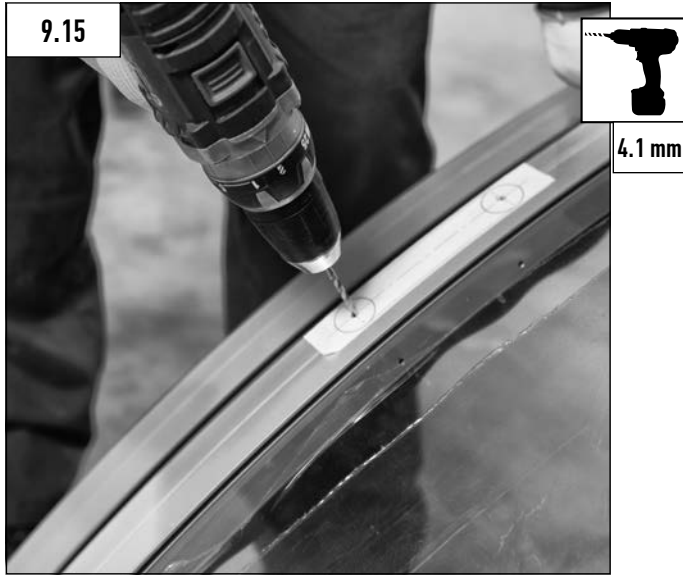
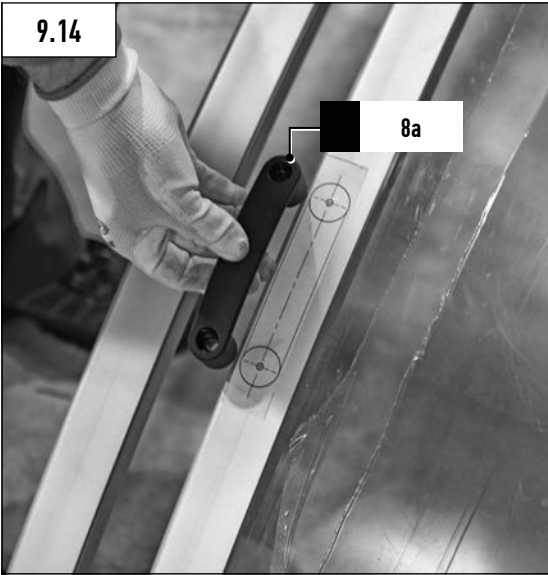
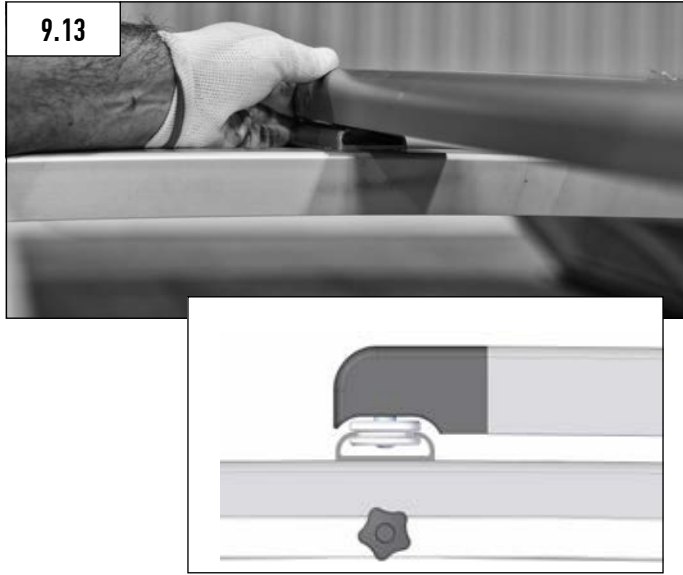

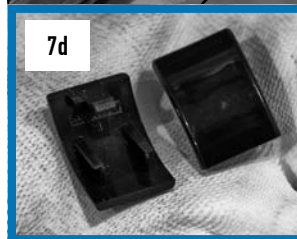
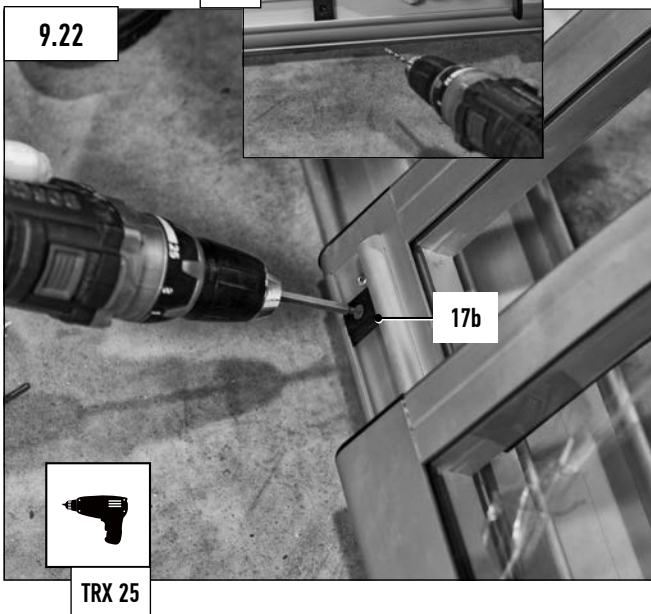
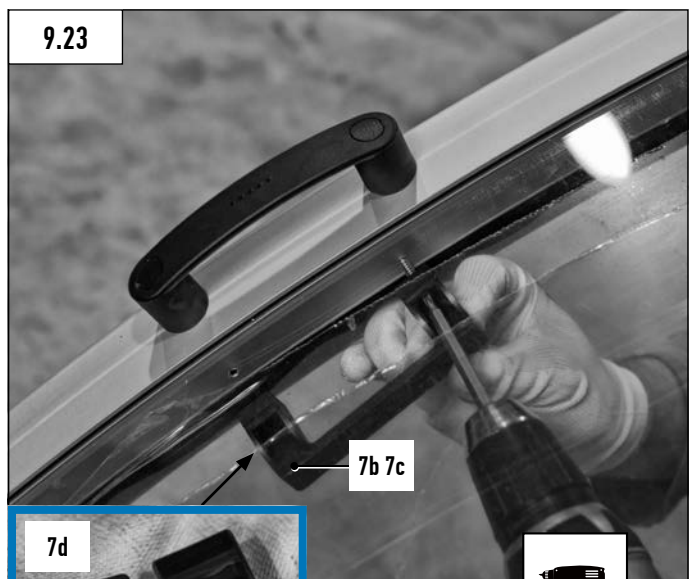
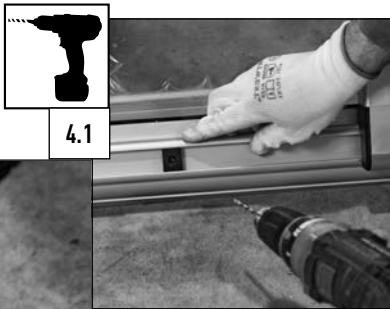
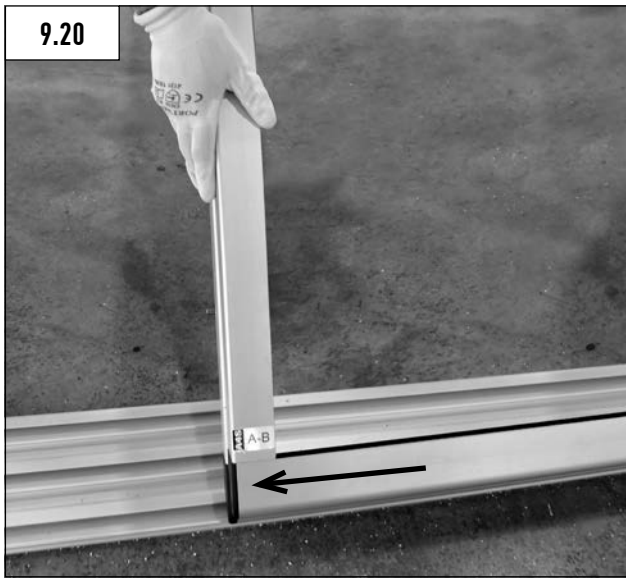
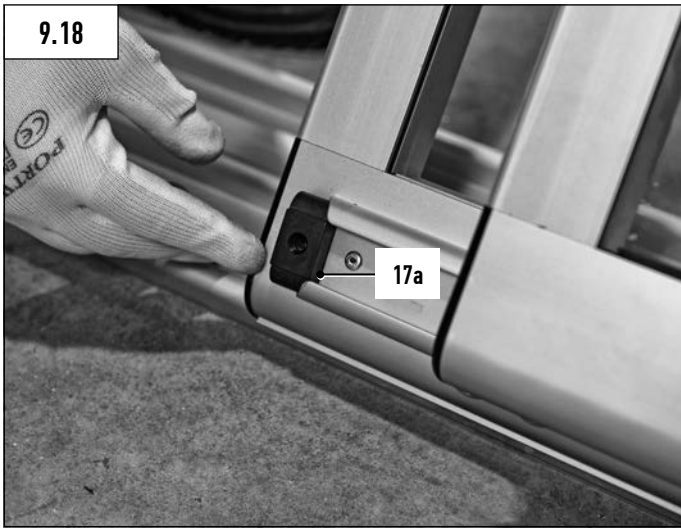



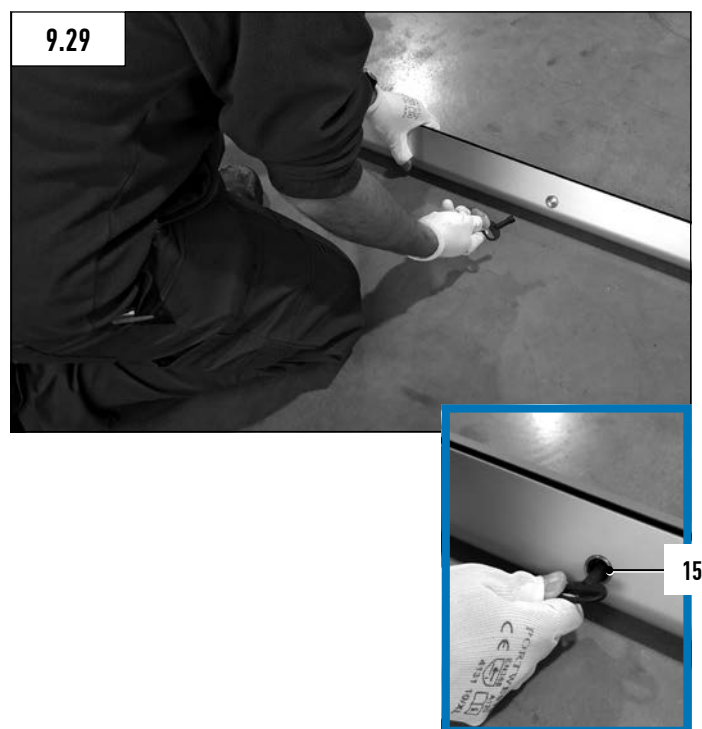
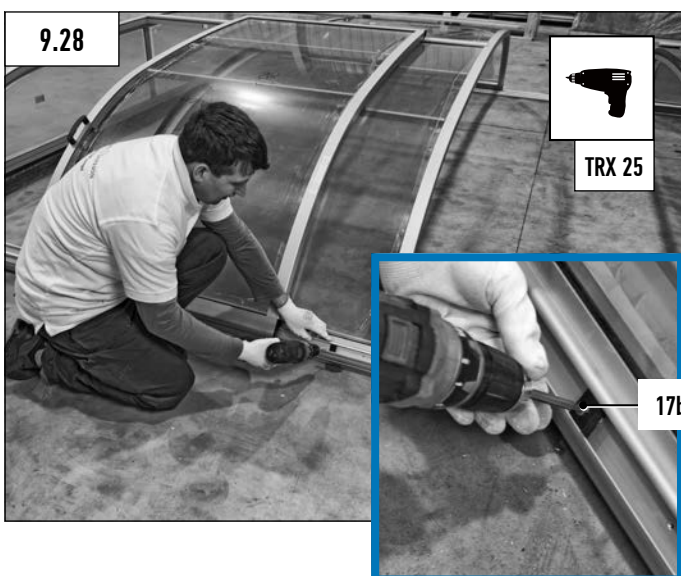
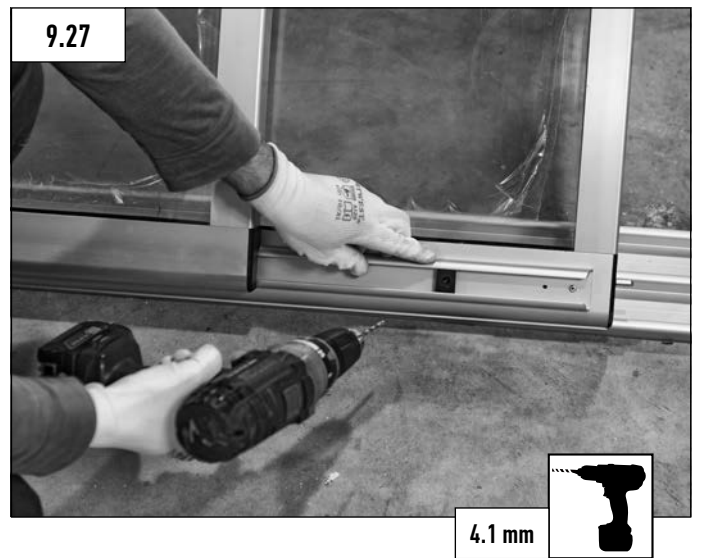

# 10 ASSEMBLAGE FINAL – POSITIONNEMENT DE VERROUILLAGE ET DES BUTÉES DE SÉCURITÉ!

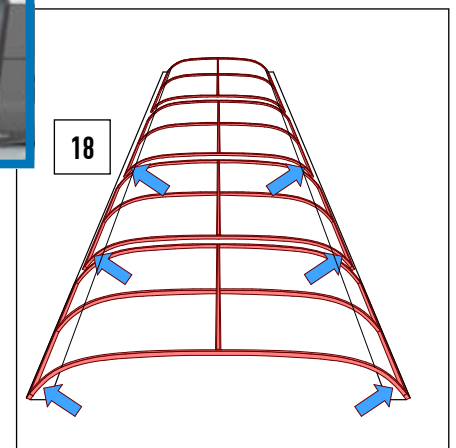
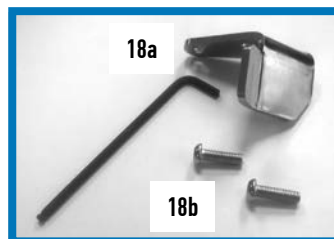
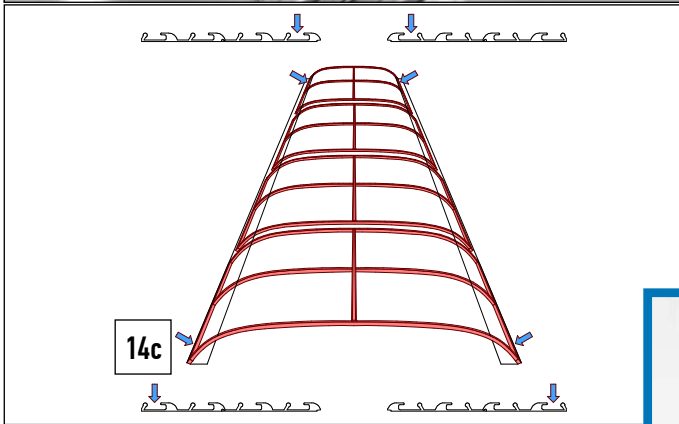
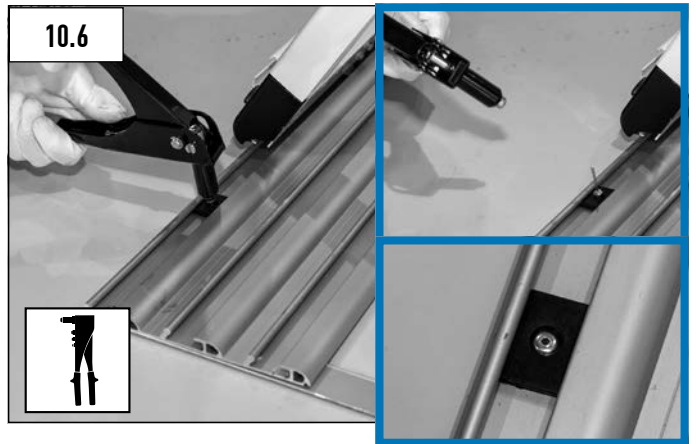
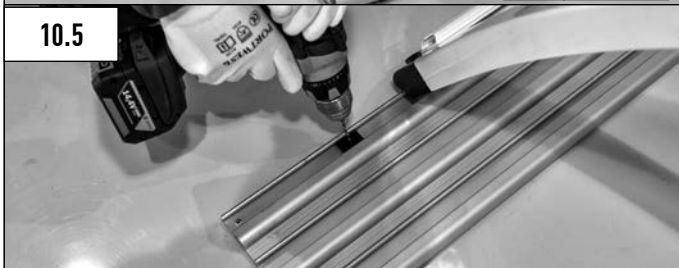
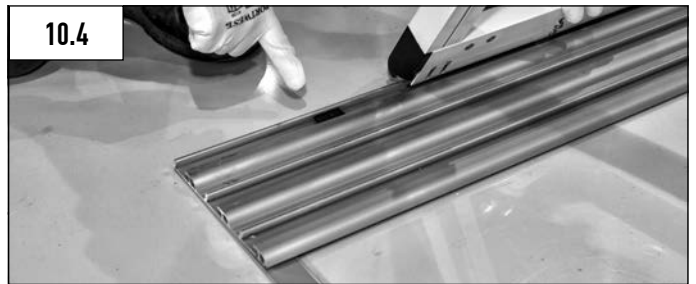
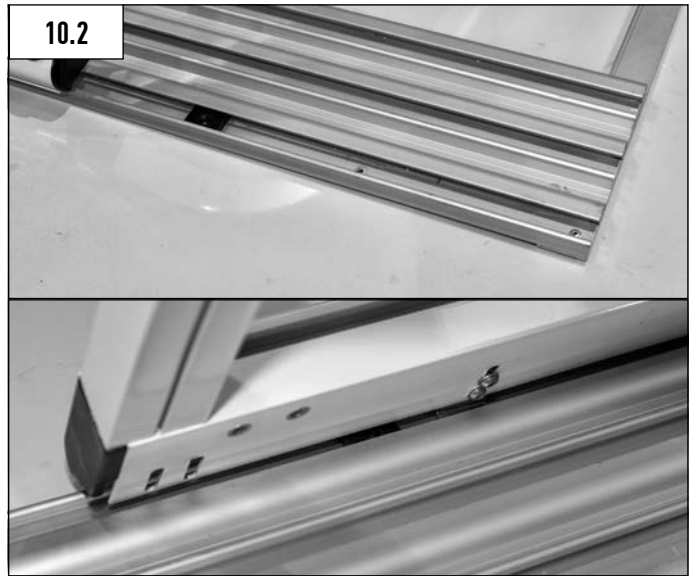
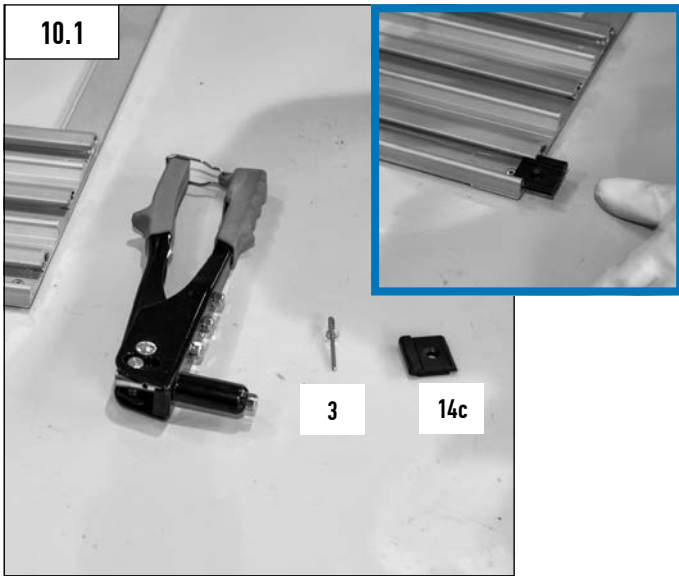

← Le front d'élément      L'arrière partie d'élément →

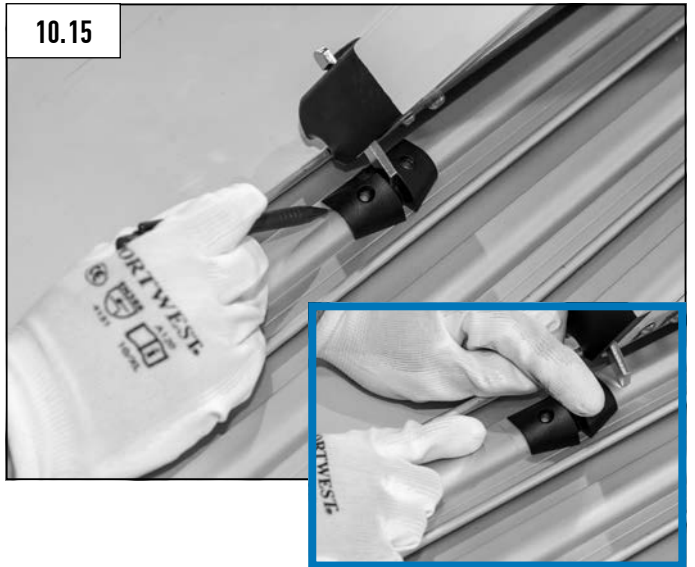
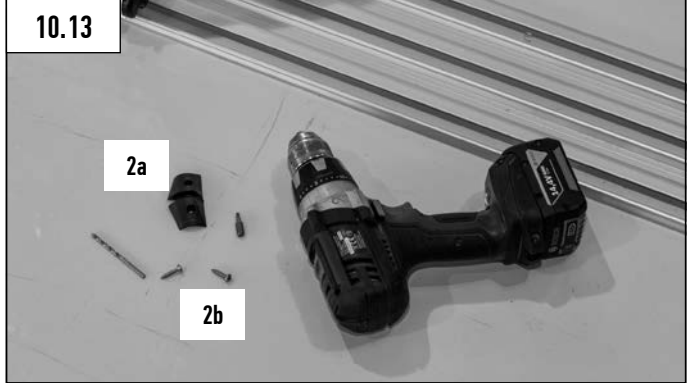
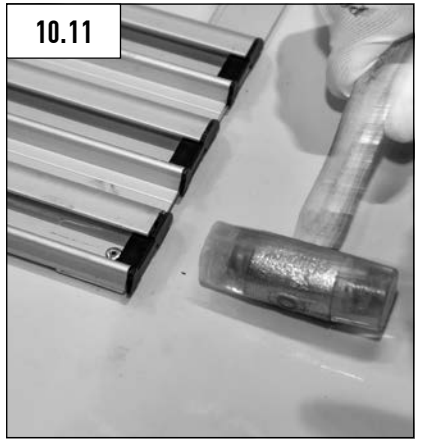
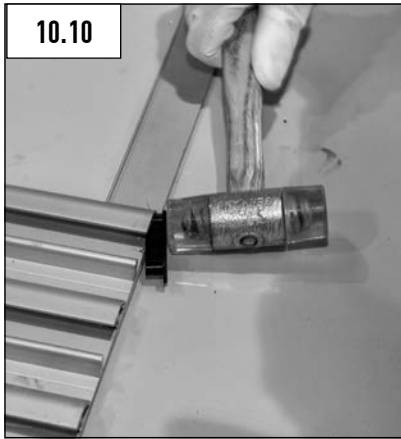
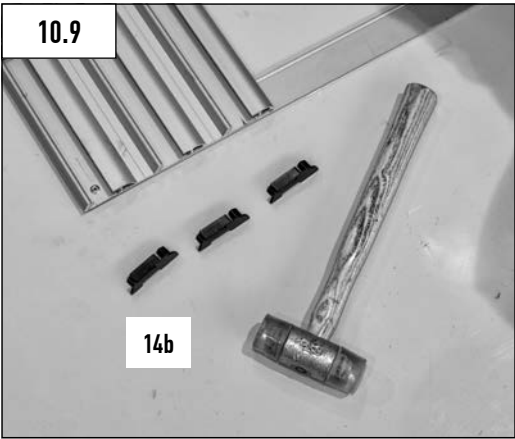
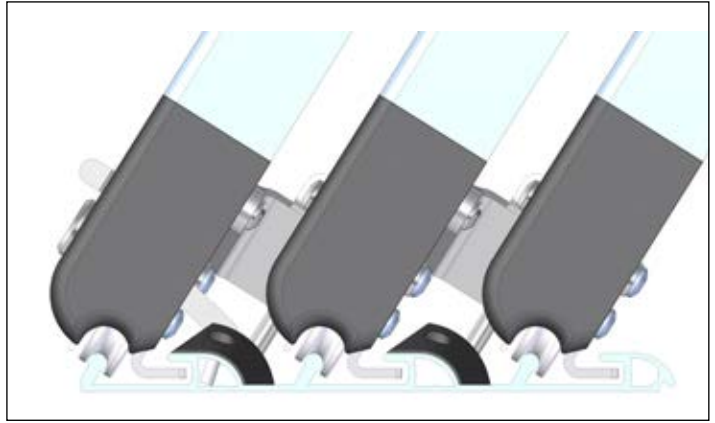

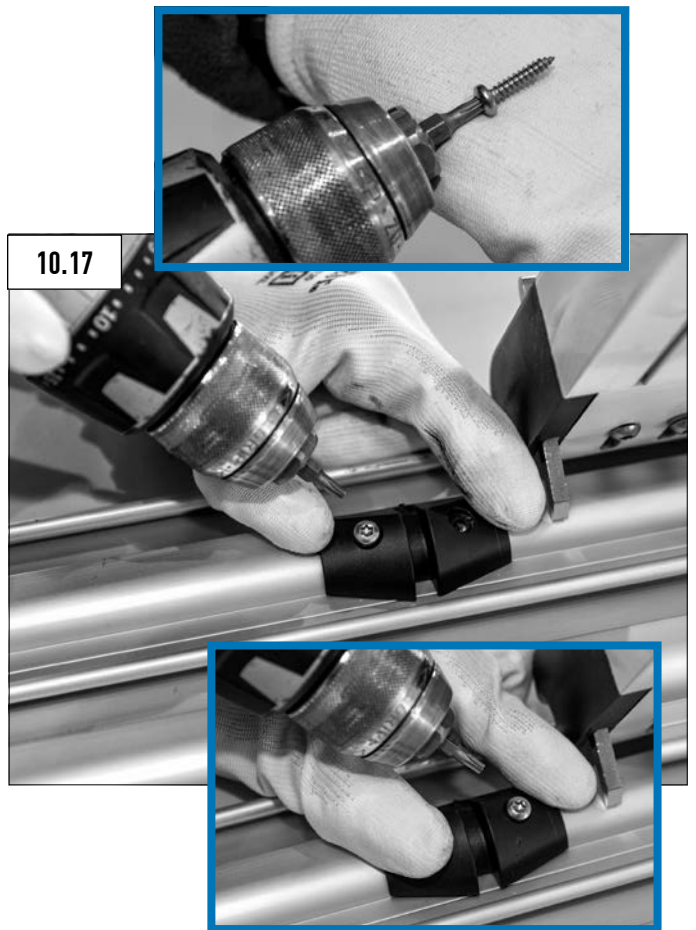
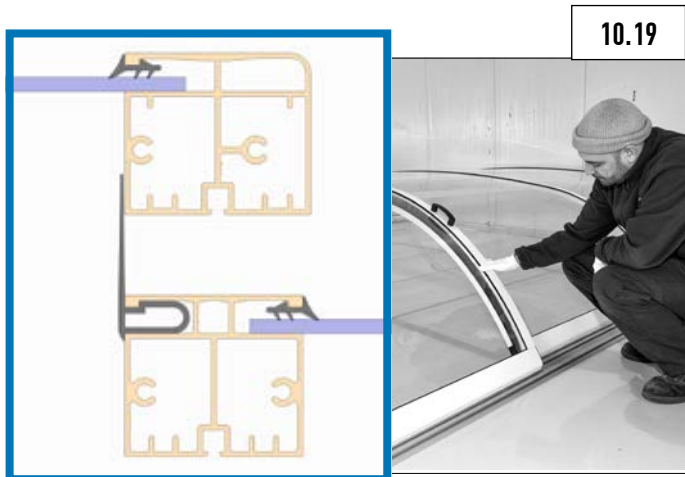
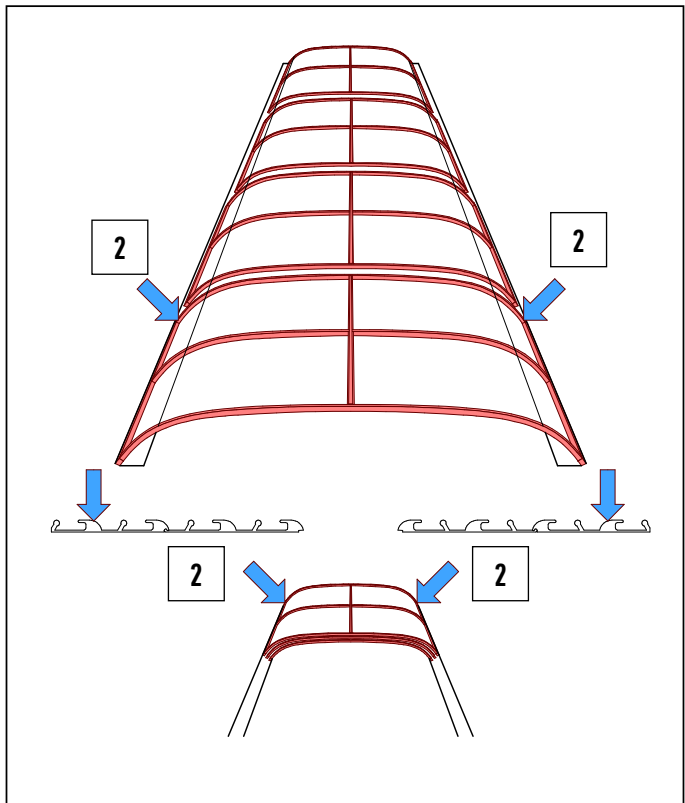

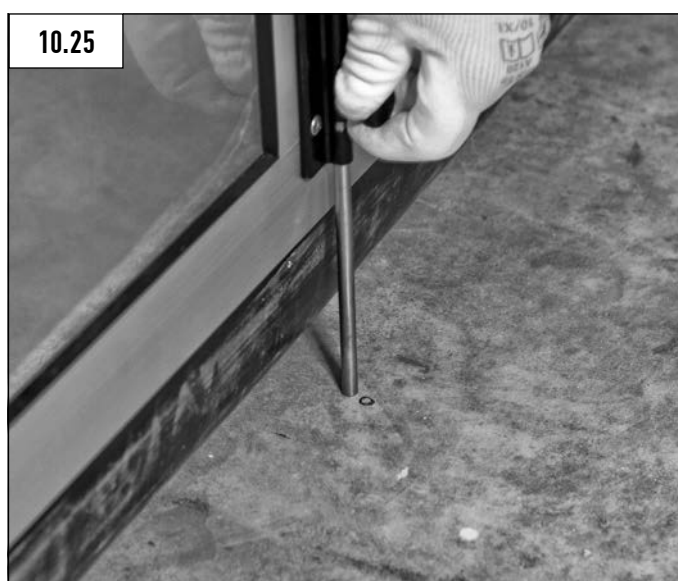
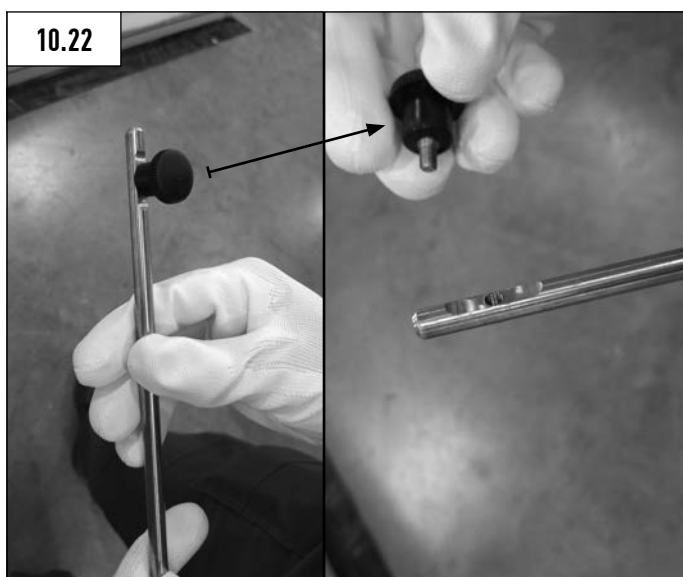
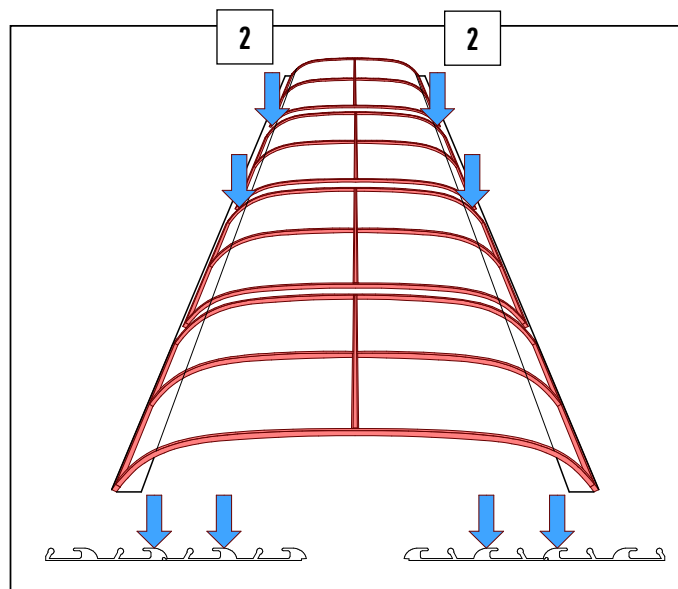

\* MODÈLES BAS = FACADE ET FOND  
 MODÈLES STANDARD = SEULEMENT FOND

